

## SES and SPC — “Smart End Seal” and “Smart Power Connection” for power line-based control and monitoring systems

The DigiTrace SES and SPC series of transmitters are used in freeze protection and process temperature maintenance applications. The system is unique in that the heating cable bus wires and power cables carry the monitoring signals. No additional field wiring is necessary.

The SES series of transmitters typically are placed at the end of a heating cable circuit to seal the end of the heating cable. The SES series comes in two types: temperature/continuity transmitter (SES-RTD) and continuity transmitter (SES-CONT).

The SPC series of transmitters typically are placed at the front of a heating cable circuit to provide a power connection to the heating cable. The SPC series comes in two types: pipe-mount (SPC-P) and wall-mount (SPC-W).

The SES-RTD, SPC-P and SPC-W transmitters replace conventional RTD sensing elements and associated wiring, sending

temperature and continuity information to the central NGC controller. The SES-CONT provides heating cable circuit continuity only.

The SES transmitter is designed for use only with 120 V and 208-277 V Raychem BTV-CR, BTV-CT, QTVR-CT, XTV-CT, KTV-CT and VPL-CT heating cables.

The SPC-P transmitter is designed for use only with 120 V and 208-277 V Raychem BTV-CR, BTV-CT, QTVR-CT, XTV-CT, KTV-CT and VPL-CT heating cables and Pyrotex Type A & D MI heating cables.

The SPC-W transmitter is designed for use with an external junction box to support all 120 V and 208-277 V heating cables that are approved for the appropriate area classification. The SPC-W transmitter also supports the direct connection of 120 V and 208-277 V Pyrotex Type A & D MI heating cables.

The SES/SPC transmitters require a programmable NGC controller, a Power Line Carrier Interface (PLI) module, and an optional power-switching contactor panel. Up to 127 strategically placed SES/SPC transmitters communicate with one PLI module (one PLI module per heat-tracing transformer). A typical controller, the NGC-30, can support up to four PLI modules.

### System Requirements

The SES/SPC system requires a dedicated heat-tracing transformer of 112.5 kVA or less and a MoniTrace 700-FEF front end filter to provide electrical noise isolation between the plant environment and the heat-tracing power. Connect only the heat tracing to the secondary of this transformer. Do not connect high power/noise sources such as variable-frequency drives to the primary of this transformer.

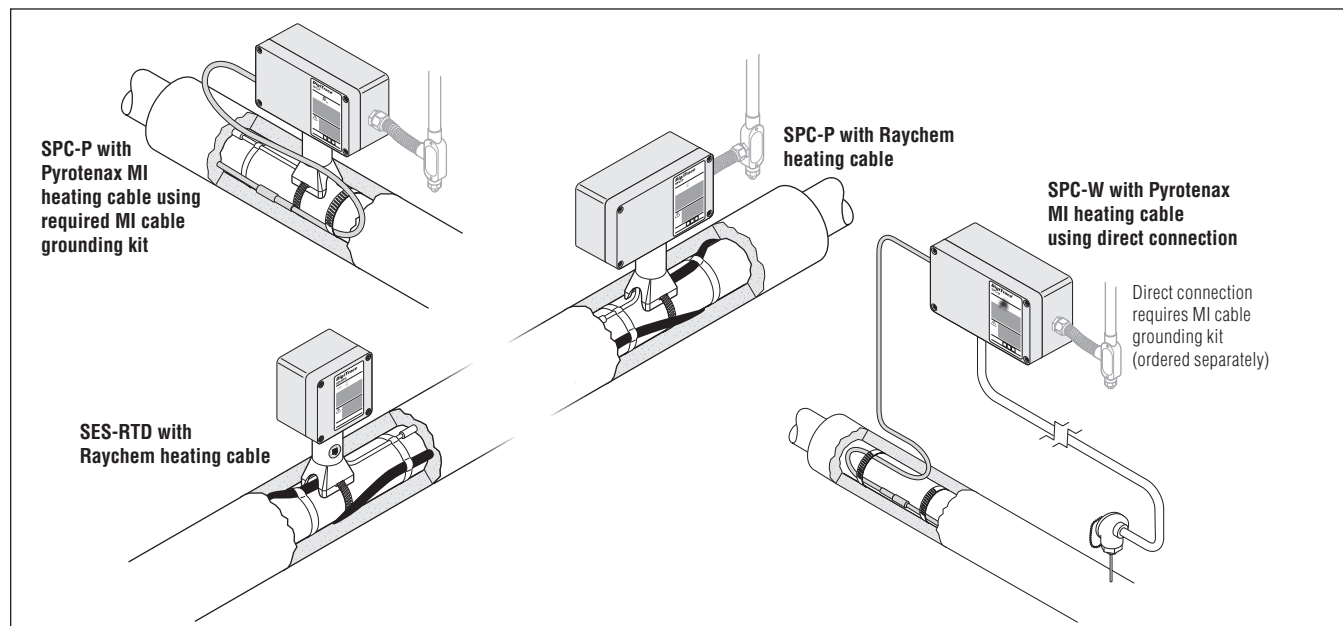

**Specifications**

Function	SES-CONT: Digital continuity transmitter SES-RTD: Digital temperature and continuity transmitter SPC-P: Digital temperature and continuity transmitter with pipe-mount power connection enclosure SPC-W: Digital temperature and continuity transmitter with wall-mount power connection enclosure
Address	Switch selectable with three rotary switches, 127 addresses, 1–127
Cables supported	SES: Raychem BTV-CR, BTV-CT, QTVR-CT, XTV-CT, KTV-CT and VPL-CT SPC-P: Raychem BTV-CR, BTV-CT, QTVR-CT, XTV-CT, KTV-CT and VPL-CT, Pyrotenax Type A & D MI SPC-W with external junction box: Heating cables that are approved for the appropriate area classification SPC-W with direct connection: Pyrotenax Type A & D MI
Cable voltage rating	120 V and 208–277 V
Maximum circuit breaker rating	50 A
Operating voltage	SES-CONT-1, SES-RTD-1, SPC-P-1, SPC-W-1: 90–132 Vac / 60 Hz SES-CONT-2, SES-RTD-2, SPC-P-2, SPC-W-2: 185–304 Vac / 60 Hz
Operating temperature range	–40°F to 140°F (–40°C to 60°C)
Enclosure rating	NEMA 4X
Maximum conductor size	SPC-P: 8 AWG
Entries	SPC-P: 1 x 0.5", 1 x 0.75" SPC-W: 1 x 0.5", 2 x 0.75"
Storage temperature range	–40°F to 167°F (–40°C to 75°C)
Temperature measurement range	SES-RTD, SPC-P: –40°F to 500°F (–40°C to 260°C) using RTD supplied with kit SPC-W: –90°F to 590°F (–68°C to 310°C) using 100 Ω platinum RTD, 3-wire, α = 0.00385 ohms/ohm/°C shielded cable of 15 Ω maximum per conductor
Temperature accuracy	± 2% of actual (± 3°F minimum)
Relative humidity	5% to 90%, noncondensing

**Approvals**

**SES:  
Hazardous Locations**



Class I, Div. 2, Groups A, B, C, D  
Class II, Div. 1 and 2, Groups E, F, G  
Class III

**SPC:  
Hazardous Locations**



Class I, Div. 2, Groups A, B, C, D  
Class II, Div. 1 and 2, Groups E, F, G  
Class III

**Line-Sensing Control and Monitoring**

Typical example of individual circuit control with NGC-30-CRM, PLI module, and SES transmitter for ground-fault trip/monitoring and temperature/heater current monitoring

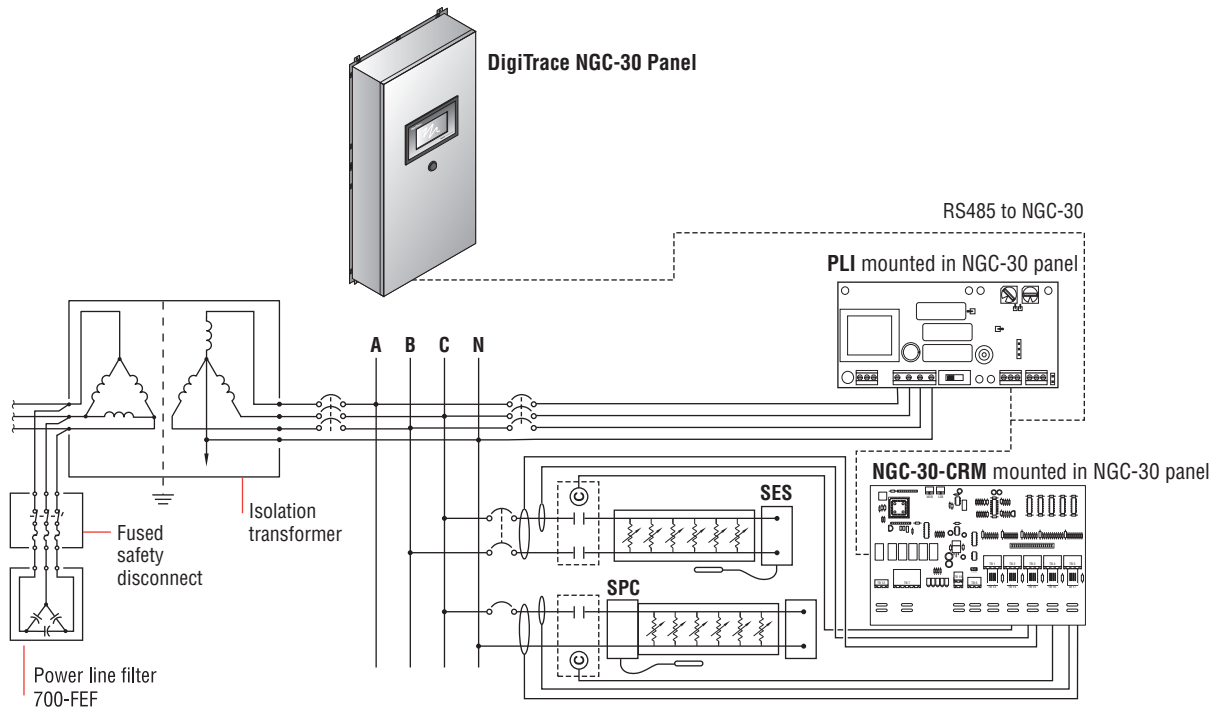

**Ordering Details**

Description	Catalog number	Part number	Weight (lbs)
120 V temperature/continuity transmitter with end seal enclosure	SES-RTD-1	265212-000	3.2
208–277 V temperature/continuity transmitter with end seal enclosure	SES-RTD-2	677596-000	3.2
120 V continuity transmitter with end seal enclosure	SES-CONT-1	293536-000	3.0
208–277 V continuity transmitter with end seal enclosure	SES-CONT-2	398720-000	3.0
120 V temperature/continuity transmitter with pipe-mount power connection enclosure	SPC-P-1	P000001049	4.4
208–277 V temperature/continuity transmitter with pipe-mount power connection enclosure	SPC-P-2	P000001050	4.4
120 V temperature/continuity transmitter with wall-mount power connection enclosure	SPC-W-1	P000001051	4.0
208–277 V temperature/continuity transmitter with wall-mount power connection enclosure	SPC-W-2	P000001052	4.0
<b>Spare parts</b>			
120 V replacement transmitter board	SES-TT-1	815918-000	0.8
208–277 V replacement transmitter board	SES-TT-2	771274-000	0.8
Replacement RTD and stand assembly	SES-RTD-Replace	693618-000	0.8

**Worldwide Headquarters  
Tyco Thermal Controls**

7433 Harwin Drive  
Houston, TX 77036  
USA  
Tel: 800-545-6258  
Tel: 650-216-1526  
Fax: 800-527-5703  
Fax: 650-474-7711  
info@tycothermal.com  
www.tycothermal.com

**Canada  
Tyco Thermal Controls**

250 West St.  
Trenton, Ontario  
Canada K8V 5S2  
Tel: 800-545-6258  
Fax: 800-527-5703

**Europe, Middle East, Africa (EMEA)  
Tyco Thermal Controls**

Romeinse Straat 14  
3001 Leuven  
België / Belgique  
Tel: +32 16 213 511  
Fax: +32 16 213 603

**Latin America  
Tyco Thermal Controls**

7433 Harwin Drive  
Houston, TX 77036  
United States  
Tel: 713-868-4800  
Tel: 713-735-8645  
Fax: 713-868-2333

**Asia Pacific  
Tyco Thermal Controls**

20F, Innovation Building,  
1009 Yi Shan Rd,  
Shanghai 200233,  
P.R.China  
Tel: +86 21 2412 1688  
Fax: +86 21 5426 2937 / 5426 3167

Tyco, Alliance Integrated Systems, AMC, AutoMatrix, AutoSol, BTV, CapaciSense, Chemelex, DHSX, DigiTrace, DigiTrace logo, DigiTrace Supervisor, Duoterm, ElectroMelt, EM2XR, FHSM, FHSC, FlexFit, FlexiClic, Flowguard, FreezeTrace, FreezGuard, Frostex, Frostex Plus, Frostguard, FroStop, FSE, Gardian, HAK, Handvise, HBTv, HCCL, HotCap, HQTv, HTPG, HTPi, HWAT, HXTv, IceStop, Interlock, Isocable, Isodrum, Isoheat, Isomantle, Isopad, Isopad Frostguard, Isopad logo, Isopanel, Isotape, Isotherm, JBM, JBS, K-Flex, K-Flex logo, KHE, KHH, KHL, KHP, KTV, Labsafe, LBTv, LHC, LHFV, LHRV, Metabond, Mini WinterGard, Miser WinterGard, MoniTrace, Multi-plus, NGC, PetroTrace, PLI, PolyMatrix, Pyro CiC, PyroFLX, Pyromaster, Pyropak, Pyrosil, PyroSizer, Pyrotenax, Pyrotenax Designer, Pyrotenax logo, QTVR, QuickNet, QuickNet logo, QuickStat, QuickTerm, RayClic, RaySol, RayStat, Retro WinterGard, RHS, RHSC, RHSM, RMM2, SBF, SBV, SC, SHC, Sheathmaster, ShowerGuard, SLBTv, Smart Heat for Comfort and Safety, SnoCalc, SnoCalc logo, STS, System 500, System 1850, System 1850-SE, System 2000, System 2200, T2, T2 logo, T2Blue, T2QuickNet, T2Red, T2Reflecta, TankCalc Plus, TempBus, Thermoheat, ThermoLimit, Thermo-Line, Total Care in Heat-tracing, Touch, Trac-Loc, Trac Calc, TraceCalc Net, TraceCalc Net logo, TraceCalc Pro logo, TraceGuard 277, TraceMaster, Tracer, Tracer logo, TRACERLYNX, TRACERLYNX logo, TraceStat, TraceTek, TraceTek logo, TruckPak, VLBTv, VLKTv, VPL, We manage the heat you need, WinterGard, WinterGard logo, WinterGard Plus, WinterGard Wet, XL-ERATE, XL-ERATE logo, XL-Trace, XTV and Zero EMI are registered and/or unregistered trademarks of Tyco Thermal Controls LLC or its affiliates.

All other trademarks are the property of their respective owners.



**Important:** All information, including illustrations, is believed to be reliable. Users, however, should independently evaluate the suitability of each product for their particular application. Tyco Thermal Controls makes no warranties as to the accuracy or completeness of the information, and disclaims any liability regarding its use. Tyco Thermal Controls' only obligations are those in the Tyco Thermal Controls Standard Terms and Conditions of Sale for this product, and in no case will Tyco Thermal Controls or its distributors be liable for any incidental, indirect, or consequential damages arising from the sale, resale, use, or misuse of the product. Specifications are subject to change without notice. In addition, Tyco Thermal Controls reserves the right to make changes—without notification to Buyer—to processing or materials that do not affect compliance with any applicable specification.