



Visit www.tycothermal.com for more information on our ten-year extended warranty.

Self-regulating pipe freeze protection and flow maintenance heating cable

Raychem® XL-Trace® is designed for pipe freeze protection and flow maintenance in the following applications:

- Freeze protection of general water piping (aboveground and buried)
- Freeze protection of fire sprinkler system standpipes (aboveground)
- Flow maintenance of greasy waste lines (aboveground and buried)
- Flow maintenance of fuel lines (aboveground)

The heating element in the XL-Trace heating cable consists of a continuous core of conductive polymer extruded between two

copper bus wires. The XL-Trace heating cable regulates its power output in response to pipe temperature changes. This self-regulating technology allows XL-Trace heating cable to be overlapped or installed on plastic pipes without overheating.

Low total installed cost

The XL-Trace heating cable's parallel circuitry allows it to be cut to the exact length required, with no wasted cable. Its flexibility allows it to be wrapped around complex fittings and valves. All of these characteristics simplify and streamline the design of a heat-tracing system. Installation is quick and simple.

Low total operating cost

Building operators are assured of optimal energy efficiency and low maintenance costs when an XL-Trace system is specified.

The same features that make an XL-Trace system easy to install the first time also simplify additions or changes to the system during building renovations.

For additional information, contact your Tyco Thermal Controls representative or call Tyco Thermal Controls at (800) 545-6258.

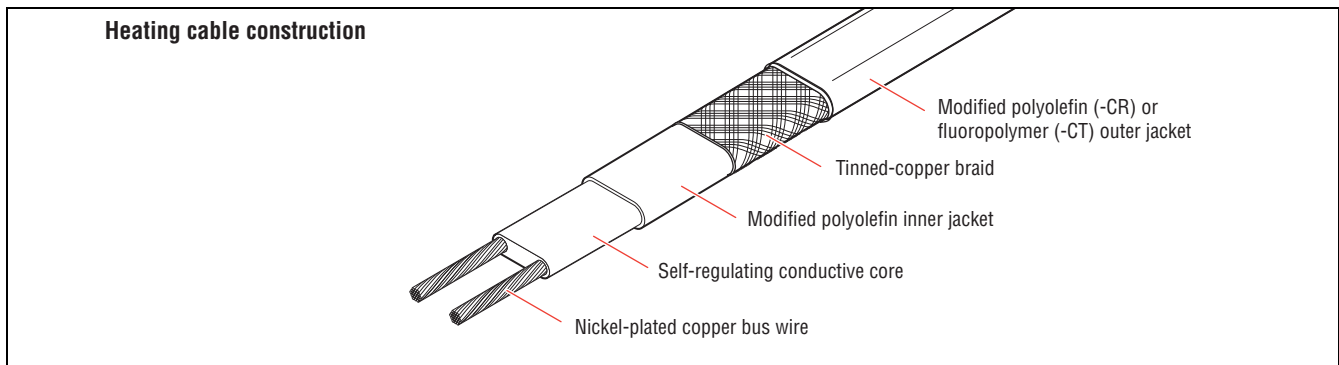

Catalog Number	5XL1-CR/CT	5XL2-CR/CT	8XL1-CR/CT	8XL2-CR/CT	12XL2-CR/CT
Voltage	120 V	208–277 V	120 V	208–277 V	208–277 V
Maximum Operating Temperature	150°F (65°C)	150°F (65°C)	150°F (65°C)	150°F (65°C)	150°F (65°C)
Maximum Exposure Temperature	150°F (65°C)	150°F (65°C)	150°F (65°C)	150°F (65°C)	185°F ¹ (85°C) ¹
Minimum Installation Temperature	0°F (–18°C)	0°F (–18°C)	0°F (–18°C)	0°F (–18°C)	0°F (–18°C)
Minimum Bend Radius	1/2 in (12 mm)	1/2 in (12 mm)	1/2 in (12 mm)	1/2 in (12 mm)	1/2 in (12 mm)

¹ When the design requires 185°F (85°C) exposure temperature, all connections must be installed off the pipe.

Maximum Circuit Length in Feet

40°F / 110°F Maintain*												
Start-up temperature (°F)	CB size (A)	5XL1	8XL1	5XL2			8XL2			12XL2		
		120 V	120 V	208 V	240 V	277 V	208 V	240 V	277 V	208 V	240 V	277 V
-20°F	15	101	76	174	178	183	131	138	146	111	114	117
	20	134	101	232	237	245	175	184	194	148	151	156
	30	201	151	349	356	367	262	276	291	223	227	234
	40	270	201	465	474	478	349	368	388	297	303	312
0°F	15	115	86	199	203	209	149	157	166	120	122	126
	20	153	115	265	271	279	199	209	221	160	163	168
	30	230	172	398	406	419	298	314	331	239	244	252
	40	270	210	470	490	530	370/399	390/420	420/443	319	326	336
20°F	15	134	100	232	237	244	173	182	192	126	129	133
	20	178	133	309	315	325	231	243	257	169	172	177
	30	270	200	464	473	488	346	365	385	253	258	266
	40	270	210	470	490	530	370/462	390/486	420/513	340/349	344	355
40°F	15	160	119	278	283	292	206	217	229	142	145	150
	20	214	159	370	378	390	275	290	306	190	194	200
	30	270	210	470	490	530	370/416	390/438	420/462	285	291	300
	40	270	210	470	490	530	370/554	390/584	420/616	340/398	360/406	380/419
50°F (buried)	15	-	-	-	-	-	228	240	254	152	155	160
	20	-	-	-	-	-	304	320	338	203	207	213
	30	-	-	-	-	-	457	481	507	304	310	320
	40	-	-	-	-	-	609	641	676	405	414	427
65°F (indoors grease)	15	-	-	-	-	-	272	286	302	169	172	178
	20	-	-	-	-	-	362	381	402	225	230	237
	30	-	-	-	-	-	543	572	603	338	345	356
	40	-	-	-	-	-	610	660	720	430	460	490

* When maximum circuit length is listed in:

- black type, the value is for applications with a 40°F maintain
- *red italic* type, the value is for applications with a 110°F maintain

Maximum Circuit Length in Meters

4°C / 43°C Maintain*												
Start-up temperature (°C)	CB size (A)	5XL1	8XL1	5XL2			8XL2			12XL2		
		120 V	120 V	208 V	240 V	277 V	208 V	240 V	277 V	208 V	240 V	277 V
-29°C	15	31	23	53	54	56	40	42	44	34	35	36
	20	41	101	71	72	75	53	56	59	45	46	48
	30	61	151	106	108	112	80	84	89	68	69	71
	40	82	201	142	145	149	106	112	118	90	92	95
-18°C	15	35	86	61	62	64	45	48	51	36	37	38
	20	47	115	81	83	85	61	64	67	49	50	51
	30	70	172	121	124	128	91	96	101	73	74	77
	40	82	210	143	149	162	113/122	119/128	128/135	97	99	102
-7°C	15	41	100	71	72	74	53	56	59	39	39	41
	20	54	133	94	96	99	70	74	78	51	52	54
	30	82	200	141	144	149	106	111	117	77	79	81
	40	82	210	143	149	162	113/141	119/148	128/156	104/106	105	108
4°C	15	49	119	85	86	89	63	66	70	43	44	46
	20	65	159	113	115	119	84	88	93	58	59	61
	30	82	210	143	149	162	113/127	119/134	128/141	87	89	91
	40	82	210	143	149	162	113/169	119/178	128/188	104/121	110/124	116/128
10°C (buried grease)	15	-	-	-	-	-	70	73	77	46	47	49
	20	-	-	-	-	-	93	98	103	62	63	65
	30	-	-	-	-	-	139	147	155	93	95	98
	40	-	-	-	-	-	186	195	206	124	126	130
18°C (indoors grease)	15	-	-	-	-	-	83	87	92	52	53	54
	20	-	-	-	-	-	110	116	123	69	70	72
	30	-	-	-	-	-	166	174	184	103	105	108
	40	-	-	-	-	-	186	201	220	131	140	149

- * When maximum circuit length is listed in:
- black type, the value is for applications with a 4°C maintain
 - *red italic* type, the value is for applications with a 43°C maintain

Nominal Power Output on Metal Pipes at 120 V/208 V

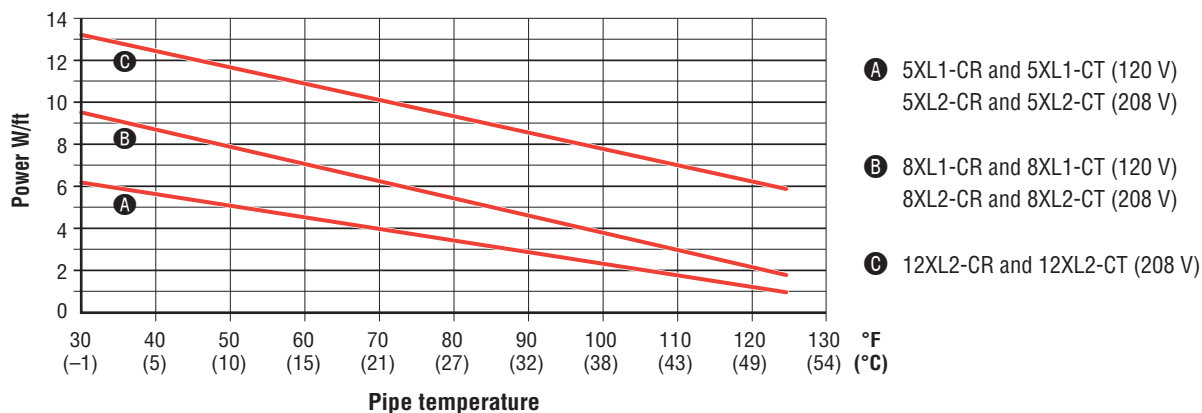

- A** 5XL1-CR and 5XL1-CT (120 V)
5XL2-CR and 5XL2-CT (208 V)
- B** 8XL1-CR and 8XL1-CT (120 V)
8XL2-CR and 8XL2-CT (208 V)
- C** 12XL2-CR and 12XL2-CT (208 V)

Bus Wires	16 AWG nickel-plated copper	
Braid/Outer Jacket	Tinned-copper braid with modified polyolefin jacket (-CR) or fluoropolymer jacket (-CT).	
Dimensions	5XL and 8XL	12XL
Maximum width	0.56 in (14 mm)	0.62 in (16 mm)
Maximum thickness	0.24 in (6 mm)	0.24 in (6 mm)
Nominal Weight	92 lb/1000 ft	104 lb/1000 ft
Connection Kits	Raychem RayClic or FTC connection kits must be used with XL-Trace heating cables. Refer to the <i>Pipe Freeze Protection and Flow Maintenance Design Guide</i> (H55838) for proper connection kit selection.	

Approvals



Ground-Fault Protection

To minimize the danger of fire from sustained electrical arcing if the heating cable is damaged or improperly installed, and to comply with the requirements of Tyco Thermal Controls, agency certifications, and national electrical codes, ground-fault equipment protection must be used on each heating cable branch circuit. Arcing may not be stopped by conventional circuit protection.

**Worldwide Headquarters
Tyco Thermal Controls**
307 Constitution Drive
Menlo Park, CA 94025-1164
USA
Tel: (800) 545-6258
Tel: (650) 216-1526
Fax: (800) 527-5703
Fax: (650) 474-7711
info@tycothermal.com
www.tycothermal.com

**Canada
Tyco Thermal Controls**
250 West St.
Trenton, Ontario
Canada K8V 5S2
Tel: (800) 545-6258
Fax: (800) 527-5703

**Latin America
Tyco Thermal Controls**
7433 Harwin Drive
Houston, TX 77036
United States
Tel: (713) 868-4800
Tel: (713) 735-8645
Fax: (713) 868-2333

**Europe, Middle East, Africa
Tyco Thermal Controls**
Romeinse Straat 14
3001 Leuven
België / Belgique
Tel: (32) 16/213 511
Fax: (32) 16/213 603

**North Asia
Tyco Thermal Controls**
20F, Innovation Building,
1009 Yi Shan Rd,
Shanghai 200233,
P.R.China
Tel: 86-21-2412-1688
Fax: 86-21-5426-2937 / 5426-3167

Tyco and other trademarks are the property of Tyco Thermal Controls or its affiliates

tyco

Thermal Controls

Important: All information, including illustrations, is believed to be reliable. Users, however, should independently evaluate the suitability of each product for their particular application. Tyco Thermal Controls makes no warranties as to the accuracy or completeness of the information, and disclaims any liability regarding its use. Tyco Thermal Controls' only obligations are those in the Tyco Thermal Controls Standard Terms and Conditions of Sale for this product, and in no case will Tyco Thermal Controls or its distributors be liable for any incidental, indirect, or consequential damages arising from the sale, resale, use, or misuse of the product. Specifications are subject to change without notice. In addition, Tyco Thermal Controls reserves the right to make changes—without notification to Buyer—to processing or materials that do not affect compliance with any applicable specification.