

**Ambient-sensing thermostat  
for hazardous locations**

The AMC-1H ambient-sensing thermostat is designed to control heat-tracing systems used for freeze protection in hazardous

locations. The thermostat responds to ambient temperature changes and has an adjustable set point. The AMC-1H can be

used to control a single heat-tracing circuit or as a pilot control of a contactor switching multiple heat-tracing circuits.

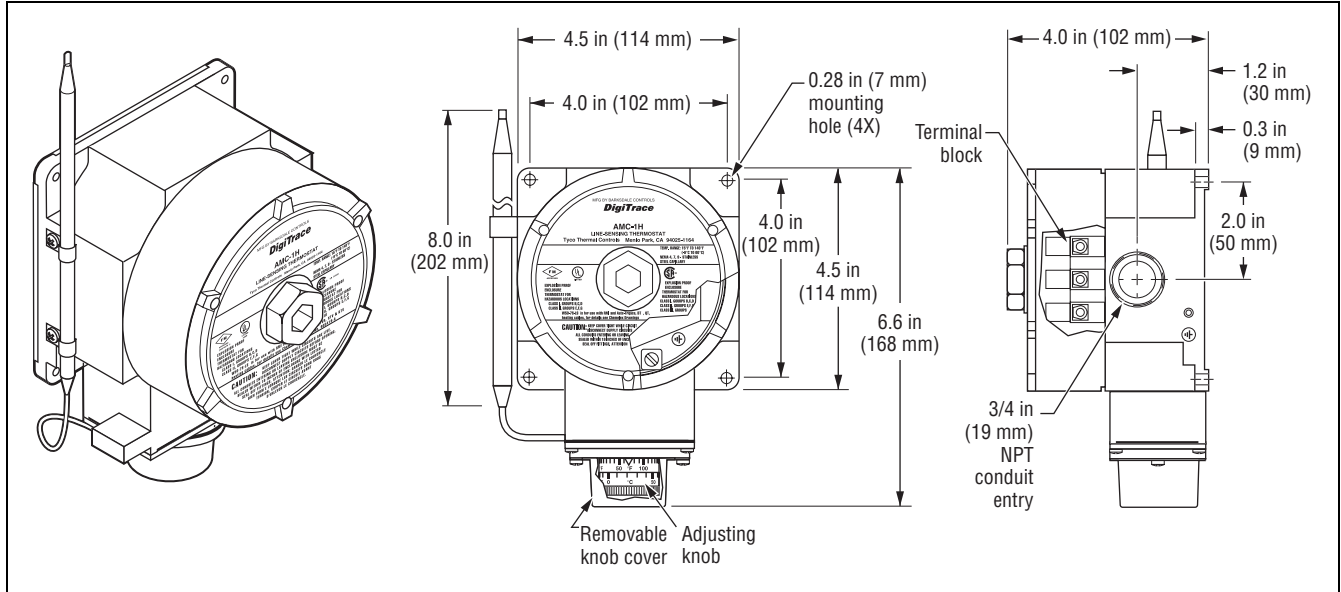

**Specifications**

Enclosure	NEMA 4, 7, 9 lacquer-coated cast-aluminum housing, stainless steel hardware
Entries	One 3/4-in (19 mm) NPT conduit hub
Set point range	15°F to 140°F (-9°C to 60°C)
Sensor exposure limits	-40°F to 160°F (-40°C to 71°C)
Housing exposure limits	-40°F to 140°F (-40°C to 60°C)
Switch	SPDT
Electrical rating	22 A at 125/250/480 Vac
Accuracy	±6°F (±3.3°C)
Deadband	2°F to 12°F (1.1°C to 6.7°C) above actuation temperature
Setpoint repeatability	±3°F (±1.7°C)
Sensor type	Fixed fluid-filled (silicone) bulb and capillary
Sensor material	300 series stainless steel
Connection terminals	Screw terminals, 10–14 AWG (2–5 mm <sup>2</sup> )

**Approvals**

**Hazardous Locations**



Class I, Div. 1 and 2, Groups B, C, D  
Class II, Div. 1 and 2, Groups E, F, G  
Class III