

RTD temperature sensor for temperature measurement up to 900°F (482°C) in Division 1 locations

The RTD7AL temperature sensor is a three-wire platinum RTD (resistance-temperature detector) typically used with monitoring

and control systems when accurate temperature control is required. The sensor is explosion-proof and approved for Division 1

hazardous locations. The RTD7AL can be used with a wide variety of DigiTrace monitoring and control systems.

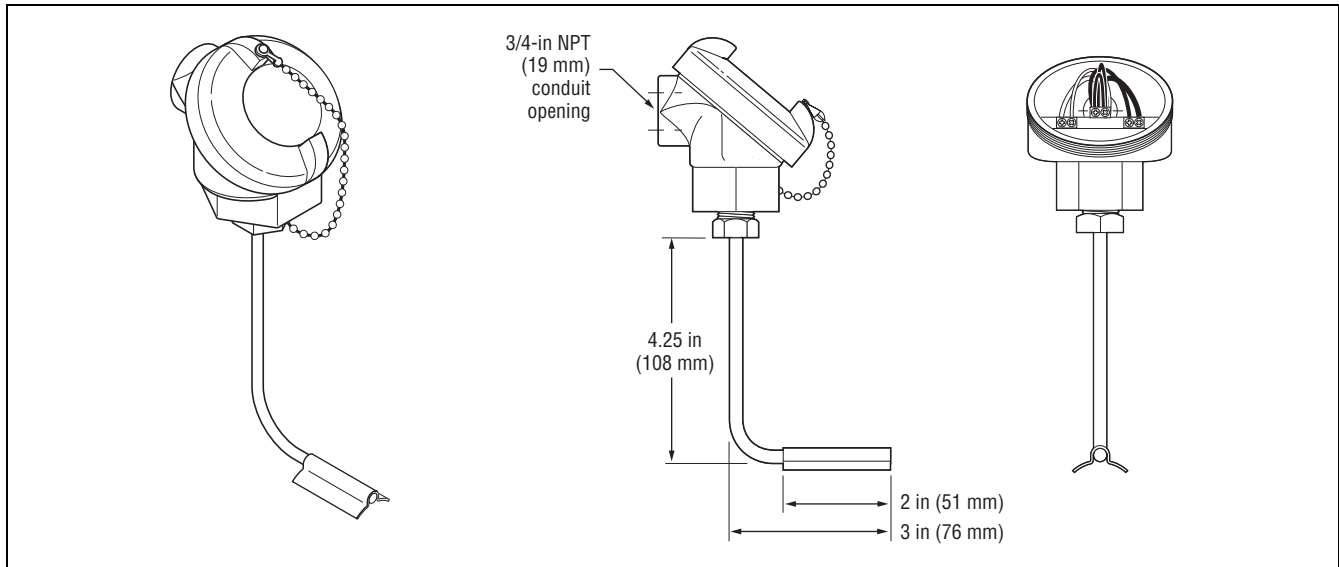

Specifications

Sensor housing	Zinc-plated cast-iron body with aluminum cap; NEMA 4, 7
Sensor sheath	316 stainless steel
Range	-100°F to 900°F (-73°C to 482°C) maximum
Accuracy	±1°F (0.5°C) at 32°F (0°C)
Resistance	100 ohms at 0°C $\alpha = 0.00385$ ohms/ohm/°C
Connection	3/4-in (19 mm) NPT conduit hub Note: The length of RTD extension wires is determined by the wire gauge used. To reduce the likelihood that electrical noise will affect temperature measurement, keep RTD extension wires as short as possible. Use shielded instrument cable such as DigiTrace MONI-RTD-WIRE (22 AWG, PVC insulation, -30°F to 140°F, -20°C to 60°C) or Belden 83553 (22 AWG, FEP insulation, -95°F to 395°F, -70°C to 200°C).

Additional Materials Required

Pipe strap, conduit, 16–22 AWG shielded instrument cable

Kit Contents

One RTD temperature sensor

Approvals

The RTD7AL is CSA certified to U.S. and Canadian standards.



Class I, Div. 1, Groups C, D
Class II, Div. 1, Groups E, F, G

**Worldwide Headquarters
Tyco Thermal Controls**

7433 Harwin Drive
Houston, TX 77036
USA
Tel: 800-545-6258
Tel: 650-216-1526
Fax: 800-527-5703
Fax: 650-474-7711
info@tycothermal.com
www.tycothermal.com

**Canada
Tyco Thermal Controls**

250 West St.
Trenton, Ontario
Canada K8V 5S2
Tel: 800-545-6258
Fax: 800-527-5703

Europe, Middle East, Africa (EMEA)

Tyco Thermal Controls
Romeinse Straat 14
3001 Leuven
België / Belgique
Tel: +32 16 213 511
Fax: +32 16 213 603

**Latin America
Tyco Thermal Controls**

7433 Harwin Drive
Houston, TX 77036
United States
Tel: 713-868-4800
Tel: 713-735-8645
Fax: 713-868-2333

**Asia Pacific
Tyco Thermal Controls**

20F, Innovation Building,
1009 Yi Shan Rd,
Shanghai 200233,
P.R.China
Tel: +86 21 2412 1688
Fax: +86 21 5426 2937 / 5426 3167

Tyco, Alliance Integrated Systems, AMC, AutoMatrix, AutoSol, BTV, CapaciSense, Chemelex, DHSX, DigiTrace, DigiTrace logo, DigiTrace Supervisor, Duoterm, ElectroMelt, EM2XR, FHSM, FHSC, FlexFit, FlexiClic, Flowguard, FreezeTrace, FreezGard, Frostex, Flostex Plus, Frostguard, FroStop, FSE, Gardian, HAK, Handvise, HBTv, HCCL, HotCap, HQTv, HTPG, HTPi, HWAT, HXTv, IceStop, Interlock, Isocable, Isodrum, Isoheat, Isomantle, Isopad, Isopad Frostguard, Isopad logo, Isopanel, Isotape, Isotherm, JBM, JBS, K-Flex, K-Flex logo, KHE, KHH, KHL, KHP, KTV, Labsafe, LBTv, LHC, LHFV, LHRV, Metabond, Mini WinterGard, Miser WinterGard, MoniTrace, Multi-plus, NGC, PetroTrace, PLI, PolyMatrix, Pyro CiC, PyroFLX, Pyromaster, Pyropak, Pyrosil, PyroSizer, Pyrotenax, Pyrotenax Designer, Pyrotenax logo, QTVR, QuickNet, QuickNet logo, QuickStat, QuickTerm, RayClic, RaySol, RayStat, Retro WinterGard, RHS, RHSC, RHSM, RMM2, SBF, SBV, SC, SHC, Sheathmaster, ShowerGuard, ShrinkCap, ShrinkSeal, ShrinkSystems, ShrinkTool, ShrinkTube, SLBTv, SnoCalc, SnoCalc logo, STS, System 500, System 1850, System 1850-SE, System 2000, System 2200, T2, T2 logo, T2Blue, T2QuickNet, T2Red, T2Reflecta, TankCalc Plus, TempBus, Thermoheat, ThermoLimit, ThermoLine, Touch, Trac-Loc, TraceCalc, TraceCalc Net, TraceCalc Net logo, TraceCalc Pro logo, TraceGard 277, TraceMaster, Tracer, Tracer logo, TracerLynx, TracerLynx logo, TraceStat, TraceTek, TraceTek logo, TruckPak, VLBTv, VLKTV, VPL, We manage the heat you need, WinterGard, WinterGard logo, WinterGard Plus, WinterGard Wet, XL-Trace, XTV and Zero EMI are registered and/or unregistered trademarks of Tyco Thermal Controls LLC or its affiliates.

All other trademarks are the property of their respective owners.

tyco
Thermal Controls

Important: All information, including illustrations, is believed to be reliable. Users, however, should independently evaluate the suitability of each product for their particular application. Tyco Thermal Controls makes no warranties as to the accuracy or completeness of the information, and disclaims any liability regarding its use. Tyco Thermal Controls' only obligations are those in the Tyco Thermal Controls Standard Terms and Conditions of Sale for this product, and in no case will Tyco Thermal Controls or its distributors be liable for any incidental, indirect, or consequential damages arising from the sale, resale, use, or misuse of the product. Specifications are subject to change without notice. In addition, Tyco Thermal Controls reserves the right to make changes—without notification to Buyer—to processing or materials that do not affect compliance with any applicable specification.