



HAX

Mineral insulated (MI) Alloy 825 heating cable

Pyrotenax HAX mineral insulated (MI) Alloy 825 series heating cables are suitable for use in hazardous areas (ATEX). They have been designed for use in freeze protection and temperature maintenance applications of pipes, tanks and other equipment.

MI heating cables of the HAX-series offer an ideal combination of ruggedness, high temperature capability and corrosion resistance and can therefore be used for a wide variety of heat-tracing applications, in particular for applications

with high power requirements and for temperatures exceeding the capabilities of polymer insulated (PI) series heating cables.

The heating cables can be used for exposure temperatures of up to 650°C and a typical power output of up to 270 W/m. Higher temperatures and power outputs can be achieved, contact Tyco Thermal Controls for assistance. HAX mineral insulated (MI) heating cables are available as single and dual conductor construction and in a very wide range

of resistances. The use of dual conductor heating cables can significantly reduce total installed cost and simplifies installation, in particular for small pipes and instrument tubing.

The heating cables are offered as bulk cable as well as factory terminated heating units employing brazing and laser welding technology. The offering is completed with a full range of components for installation, connection and splicing of the heating cables.

Heating cable construction

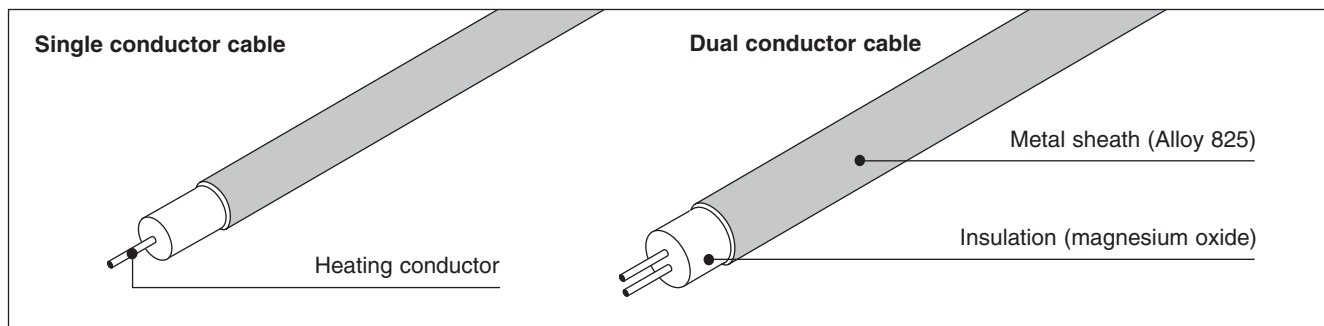

Application

Area classification	Hazardous area, Zone 1 or Zone 2 Ordinary
Approvals	System (heating units) Baseefa02ATEX0046X II 2 G EEx e II T6 to T1 CE1180 Bulk cable Baseefa02ATEX0045U II 2 G EEx e II Temperature classification (T-rating) has to be established by using the principles of stabilised design or the use of a temperature limiting device. Use TraceCalc design software or contact Tyco Thermal Controls

Technical data

Cable sheath material	Alloy 825		
Conductor material	Various alloys and copper		
Max. exposure temperature	650°C* (heating cable) 550°C (brazed heating units) 650°C* (laser welded heating units) * higher temperatures can be realised, contact Tyco Thermal Controls		
Min. installation temperature	-60°C		
Min. bending radius	6 x OD (cable diameter) at -60°C		
Max. supply voltage and power output	Voltage (U₀/U) 600/600 V AC 300/300 V AC 600/600 V AC	Max. power output* 210 W/m 200 W/m 270 W/m *typical value, depending on application	Heating cable type HAX1N Single conductor cable, 600 V HAX2M Dual conductor cable, 300 V HAX2N Dual conductor cable, 600 V
Earth leakage	3mA /100m (nominal at 20°C)		
Min. cable spacing	25 mm for hazardous areas		

Table 1 MI series heating cables HAX2M (Dual conductor cable, 300 V)

Order Reference	Nominal Resistance (Ω/km @ 20°C)	Outer Diameter (mm)	Temp. Coefficient ($\times 10^{-3}/\text{K}$)	Max. Segment Length (m)	Nom. Weight (kg/km)	Part Number PN
HAF2M36K	36000	3.2	0.09	628	45.1	32SF1110
HAF2M29.5K	29500	3.6	0.09	542	52.2	32SF2900
HAF2M24.5K	24500	3.9	0.09	431	65.8	32SF2750
HAA2M19.7K	19700	3.4	0.085	632	49.3	32SA2600
HAA2M13.2K	13200	3.7	0.085	500	57.0	32SA2400
HAA2M9000	9000	3.7	0.085	501	57.9	32SA2275
HAA2M6600	6600	4.6	0.085	329	88.2	32SA2200
HAA2M5600	5600	4.5	0.085	384	75.9	32SA2170
HAB2M3750	3750	4.7	0.04	315	87.8	32SB2114
HAB2M2300	2300	4.1	0.04	419	71.4	32SB3700
HAQ2M1560	1560	4.7	0.5	317	85.6	32SQ3472
HAQ2M1240	1240	4.7	0.5	317	85.9	32SQ3374
HAQ2M965	965	4.7	0.5	314	87.4	32SQ3293
HAQ2M660	660	3.7	0.5	503	58.6	32SQ3200
HAQ2M495	495	4.1	0.5	419	71.3	32SQ3150
HAQ2M330	330	4.6	0.5	332	91.7	32SQ3100
HAP2M240	240	4.6	1.3	316	89.9	32SP4734
HAP2M190	190	4.7	1.3	317	91.2	32SP4583
HAP2M150	150	4.7	1.3	315	94.1	32SP4458
HAC2M105	105	4.6	3.9	315	87.5	32SC4324

 Resistance tolerance: $\pm 10\%$.

Table 2 MI series heating cables HAX2N (Dual conductor cable, 600 V)

Order Reference	Nominal Resistance (Ω/km @ 20°C)	Outer Diameter (mm)	Temp. Coefficient ($\times 10^{-3}/\text{K}$)	Max. Segment Length (m)	Nom. Weight (kg/km)	Part Number PN
HAF2N36K	36000	5.2	0.09	229	119.1	62SF1110
HAF2N29.5K	29500	5.5	0.09	229	119.4	62SF2900
HAF2N19.7K	19700	5.5	0.09	230	119.9	62SF2600
HAA2N13.6K	13600	5.8	0.09	186	132.3	62SA2414
HAF2N6600	6600	6.3	0.09	177	158.8	62SF2200
HAT2N3750	3750	5.7	0.18	186	132.2	62ST2115
HAB2N2300	2300	6.8	0.04	151	186.9	62SB3700
HAQ2N1670	1670	5.7	0.5	194	127.2	62SQ3505
HAQ2N940	940	6.0	0.5	176	141.5	62SQ3286
HAQ2N660	660	6.3	0.5	177	157.7	62SQ3200
HAQ2N495	495	6.3	0.5	177	159.2	62SQ3150
HAQ2N330	330	6.7	0.5	152	189.4	62SQ3100
HAP2N255	255	6.4	1.3	151	166.1	62SP4775
HAP2N185	185	6.7	1.3	138	183.8	62SP4561
HAP2N130	130	7.1	1.3	124	206.4	62SP4402
HAP2N92	92	7.5	1.3	110	236.2	62SP4281
HAC2N66	66	7.5	3.9	131	217.4	62SC4200
HAC2N43	43	7.9	3.9	115	252.1	62SC4130
HAC2N27	27	8.7	3.9	98	297.2	62SC5818
HAC2N17	17	9.2	3.9	81	267.3	62SC5516
HAC2N10.5	10.5	10.2	3.9	67	468.0	62SC5324
HAC2N6.6	6.6	12.6	3.9	46	706.6	62SC5204
HAC2N4.3	4.3	13.8	3.9	143	837.1	62SC5128

 Resistance tolerance: $\pm 10\%$.

Table 3 MI series heating cables HAX1N (Single conductor cable, 600 V)

Order Reference	Nominal Resistance (Ω/km @ 20°C)	Outer Diameter (mm)	Temp. Coefficient ($\times 10^{-3}/\text{K}$)	Max. Segment Length (m)	Nom. Weight (kg/km)	Part Number PN
HAA1N6565	6565	3.7	0.085	519	52.8	61SA2200
HAA1N5250	5250	4.1	0.085	436	67.3	61SA2160
HAA1N4300	4300	4.1	0.085	415	67.6	61SA2130
HAA1N3300	3300	4.0	0.085	416	68.0	61SA2100
HAA1N2800	2800	4.3	0.085	368	77.1	61SA3850
HAA1N2300	2300	4.1	0.085	417	69.1	61SA3700
HAA1N1640	1640	4.5	0.085	329	88.1	61SA3500
HAT1N920	920	4.6	0.18	317	87.1	61ST3280
HAB1N660	660	4.6	0.04	330	88.7	61SB3200
HAB1N500	500	4.6	0.04	331	90.6	61SB3150
HAQ1N390	390	4.7	0.5	317	86.5	61SQ3118
HAQ1N240	240	4.7	0.5	314	88.4	61SQ4732
HAQ1N190	190	4.6	0.5	315	89.1	61SQ4581
HAP1N155	155	4.7	1.3	317	87.1	61SP4467
HAP1N120	120	4.7	1.3	314	88.4	61SP4366
HAP1N95	95	4.7	1.3	315	89.1	61SP4290
HAP1N76	76	4.6	1.3	342	89.9	61SP4231
HAP1N60	60	4.7	1.3	316	91.1	61SP4183
HAP1N48	48	4.7	1.3	317	92.1	61SP4145
HAP1N37	37	4.7	1.3	335	96.0	61SP4113
HAC1N21.3	21.3	4.9	3.9	305	102.2	61SC5651
HAC1N13.5	13.5	5.1	3.9	294	107.3	61SC5409
HAC1N8.5	8.5	5.6	3.9	233	133.8	61SC5258
HAC1N5.3	5.3	6.9	3.9	158	214.6	61SC5162
HAC1N3.3	3.3	6.4	3.9	171	197.6	61SC5102
HAC1N2	2.0	8.1	3.9	115	311.0	61SC6640

 Resistance tolerance: $\pm 10\%$.

Table 4 Recommended cold lead cables for HAX MI series heating cables

Nominal Cross section (mm ²)	Reference Single Conductor Cable	Reference Dual Conductor Cable	Max. Current Design B* (single cond.)	Max. Current Design D. E* (dual cond.)	Nominal Diameter Single cond. (mm)	Nominal Diameter Dual cond. (mm)
1.0	–	AC2H1.0	–	18	–	7.3
2.5	AC1H2.5	AC2H2.5	34	28	5.3	8.7
6.0	AC1H6	AC2H6	57	46	6.4	14.0
16	AC1H16	AC2H16	102	98	9.0	14.7
25	AC1H25	AC2H25	133	128	9.6	17.1

 All cold lead cables can be used for up to 600 V AC and use copper conductors with a temperature coefficient of $3.9 \times 10^{-3} 1/\text{K}$.

* For different heating unit designs refer to page 86.

Notes:

Delivery length depends on type of resistance and is limited by max. segment length. Not all resistances are standard items and as such may not be in stock. Contact Tyco Thermal Controls to confirm lead time. Tyco Thermal Controls requires the use of a 30 mA residual current device to provide maximum safety and protection from fire. Where design results in a higher leakage current, a maximum 300 mA residual current device may be used. All safety aspects need to be proven.



Table 5 Chemical resistance

Alloy	Description	Nominal chemical composition, % (major elements)				Thermal conductivity Btu-in W/m-C		High temperature resistance (+540°C)		Corrosion resistance G-E = Good to excellent A = Acceptable NR = Not recommended X = Check for specific data											
		Nickel (+Cobalt)	Iron	Chromium	Other	20°C	815°C	Oxidation	Carburization	Sulfuric acid	Hydrochloric acid	Hydrofluoric acid	Phosphoric acid	Nitric acid	Organic acid	Alkalies	Salts	Seawater	Chloride cracking		
INCOLOY Alloy 825 nickel-iron-chromium	Excellent resistance to a wide variety of corrosives. Resists pitting and intergranular type corrosion, reducing acids and oxidizing chemicals	42.0	30.0	21.5	Mo 3.0 Cu 2.2	11.1	23.6	G-E	G-E	G-E	G-E	G-E	G-E	G-E	G-E	G-E	G-E	G-E	G-E		

* From Huntington Alloys Publication 78-348-2
Corrosion resistance data is dependent on temperature and concentration.