

## **Installation and Maintenance Manual**

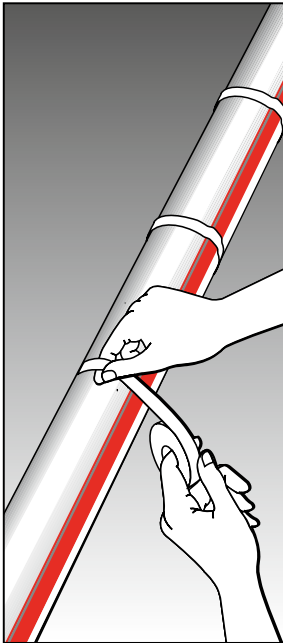

**Constant Wattage  
Parallel Circuit  
Heating Cable  
Systems**

---

1	General information	Pg. 1
2	Heating cable selection	Pg. 5
3	Heating cable installation	Pg. 6
4	Components installation	Pg. 16
5	Thermostats	Pg. 18
6	Thermal insulation and marking	Pg. 19
7	Power supply and electrical protection	Pg. 21
8	Heating cable testing	Pg. 21
9	Operation, maintenance and pipe repairs	Pg. 23
10	Heating cable damage	Pg. 24
11	Troubleshooting guide	Pg. 24

# General information

## Use of the manual

The Installation and Maintenance manual is for Raychem constant wattage parallel circuit heating cable systems on thermally insulated pipes and vessels only. For information regarding other applications contact your Tyco Thermal Controls representative.

## Heating Cable Technology

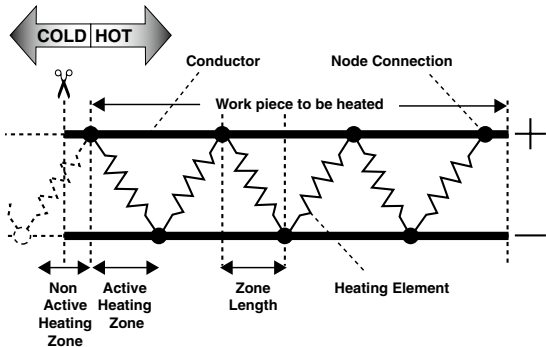

## Important

For the warranty to apply, the instructions that are included in this manual and product packages must be followed. The installation must also be compatible with local requirements applicable to electric heat tracing systems.

## Area Classification - Ordinary

FMT	Rated Voltage: 220-277 Vac
FHT2	Rated Voltage: 220-277 Vac
FHT4	Rated Voltage: 385-415 Vac

## Area Classification - Hazardous, Zone 1, Zone 2, Zone 21 or 22

Baseefa Ltd.

Certificate No. and Coding:

Baseefa 08 ATEX 0050X  II 2 GD Ex e II T\* Ex tD A21 IP 66  
IECEx BAS08.0019 Ex II 2 GD Ex e II T\* Ex tD A21 IP 66  
\* = by design

Special conditions for safe use:

1. The following limiting temperatures for the exposure of the end seals and splices shall not be exceeded: 180°C continuous operation and 200°C intermittent operation for the E-150-F and CS-150-F
2. The assembly of glands, splices and end terminations shall be carried out in accordance with the installation instructions
3. The heating element supply circuit must include an electrical protection device in conformity with clause 4.3 of EN/IEC 60079-30-1: 2007
4. The minimum bending radius is 25 mm for the types FMT and FHT cables
5. The supply of the heating unit must be terminated in a suitably certified terminal enclosure

	<b>FMT</b>	<b>FHT</b>
Minimum Bending Radius at Minimum Installation Temperature	25 mm	25 mm
Minimum Installation Temperature	-40°C	-60°C
Maximum Withstand Temperature (continuous, de-energised)	200°C	260°C
Temperature classification	Refer to design tables below or use Tyco Thermal Controls design software	Refer to design tables below or use Tyco Thermal Controls design software
Minimum cable spacing between turns	50 mm	50 mm

### Design tables for non-hazardous areas

	Maximum allowed surface temperature (°C) (= limiter setpoint)		
	<b>230 V a.c.</b>	<b>254 V a.c.</b>	<b>277 V a.c.</b>
10FMT2-CT	158	153	144
20FMT2-CT	129	116	97
30FMT2-CT	94	71	36
10FHT2-CT	229	225	219
20FHT2-CT	209	199	187
30FHT2-CT	184	168	143
40FHT2-CT	154	130	87

	Maximum allowed surface temperature (°C) (= limiter setpoint)		
	<b>385 V a.c.</b>	<b>400 V a.c.</b>	<b>415 V a.c.</b>
10FHT4-CT	250	250	249
20FHT4-CT	224	221	218
30FHT4-CT	212	208	205

### Design tables for hazardous areas

<b>230 V a.c.</b>	Maximum allowed surface temperature (°C) (= limiter setpoint)				
	T6 (85°C)	T5 (100°C)	T4 (135°C)	T3 (200°C)	T2 (260°C)
10FMT2-CT	8	26	69	147	-
20FMT2-CT	-	-	19	109	-
30FMT2-CT	-	-	-	65	-
10FHT2-CT	8	26	69	147	225
20FHT2-CT	-	-	19	109	200
30FHT2-CT	-	-	-	65	169
40FHT2-CT	-	-	-	8	131

<b>254 V a.c.</b>	Maximum allowed surface temperature (°C) (= limiter setpoint)				
	T6 (85°C)	T5 (100°C)	T4 (135°C)	T3 (200°C)	T2 (260°C)
10FMT2-CT	-	12	56	137	-
20FMT2-CT	-	-	-	88	-
30FMT2-CT	-	-	-	23	-
10FHT2-CT	-	12	56	137	218
20FHT2-CT	-	-	-	88	185
30FHT2-CT	-	-	-	23	140
40FHT2-CT	-	-	-	-	81

<b>277 V a.c.</b>	Maximum allowed surface temperature (°C) (= limiter setpoint)				
	T6 (85°C)	T5 (100°C)	T4 (135°C)	T3 (200°C)	T2 (260°C)
10FMT2-CT	-	-	37	122	-
20FMT2-CT	-	-	-	53	-
30FMT2-CT	-	-	-	-	-
10FHT2-CT	-	-	37	122	207
20FHT2-CT	-	-	-	53	161
30FHT2-CT	-	-	-	-	90
40FHT2-CT	-	-	-	-	-

<b>385 V a.c.</b>	Maximum allowed surface temperature (°C) (= limiter setpoint)				
	T6 (85°C)	T5 (100°C)	T4 (135°C)	T3 (200°C)	T2 (260°C)
10FHT4-CT	34	52	94	171	249
20FHT4-CT	-	-	40	128	216
30FHT4-CT	-	-	-	105	202

<b>400 V a.c.</b>	Maximum allowed surface temperature (°C) (= limiter setpoint)				
	T6 (85°C)	T5 (100°C)	T4 (135°C)	T3 (200°C)	T2 (260°C)
10FHT4-CT	30	48	90	169	247
20FHT4-CT	-	-	30	121	212
30FHT4-CT	-	-	-	95	195

<b>415 V a.c.</b>	Maximum allowed surface temperature (°C) (= limiter setpoint)				
	T6 (85°C)	T5 (100°C)	T4 (135°C)	T3 (200°C)	T2 (260°C)
10FHT4-CT	25	44	87	166	246
20FHT4-CT	-	-	18	112	206
30FHT4-CT	-	-	-	82	187

⚠ **Warning**

**As with any electrical equipment or wiring installation operating at line voltages, heating cable and component damage or incorrect installation that allows the penetration of moisture or contamination can lead to electrical tracking, arcing and potential fire hazard.**

**Do not connect heating cable conductors together or this will result in a short circuit.**

**Any unconnected heating cable end must be sealed with an approved end seal.**

**To prevent fire or explosion in hazardous areas, verify that the maximum sheath temperature of the heating cable is below the auto-ignition temperature of the gases in the area. For further information, see design documentation.**

## 2 Heating cable selection

---

Check the design specification to make sure the proper heating cable is installed on each pipe or vessel. Refer to Tyco Thermal Controls product literature to select the proper heating cable for each thermal, chemical, electrical and mechanical environment.

# 3

## Heating cable installation

---

### 3.1 Heating cable storage

- ▶ Store the heating cable in a clean, dry place
  - ▶ Temperature range:  $-40^{\circ}\text{C}$  to  $+60^{\circ}\text{C}$
  - ▶ Protect the heating cable from mechanical damage
- 

### 3.2 Pre-installation checks

Check materials received:

---

- ▶ Review the heating cable design and compare the list of materials to the catalogue numbers of heating cables and electrical components received to confirm that proper materials are on site. The heating cable type is printed on its outer jacket.
  - ▶ Temperature exposure must not exceed that specified in the product literature. Exceeding these limits will impair product performance. Check that expected exposure is within these limits.
  - ▶ Ensure that the heating cable voltage rating is suitable for the service voltage available.
  - ▶ Do not energize cable when it is coiled or on the reel.
  - ▶ Inspect heating cable and components for in-transit damage. An insulation resistance test (see section 8) on each reel is recommended.
- 

Check piping to be traced:

- ▶ Ensure all pressure testing is complete and pipework has final paint coating.
- ▶ Walk the system and plan the routing of the heating cable on the pipe.
- ▶ Check pipework against specification drawing. If different consult design authority.

- ◆ Inspect piping for burrs, rough surfaces, sharp edges etc. which could damage the heating cable. Smooth off or cover with layers of glass cloth tape or aluminium foil.
- 

### 3.3 Heating cable handling

Heating cable handling tips:

- ◆ Paint and pipe coatings must be dry to the touch before heating cable installation.
- ◆ When pulling the heating cable, **avoid**:
  - ◇ sharp edges
  - ◇ excessive pulling force
  - ◇ kinking and crushing
  - ◇ walking on it, or running over it with equipment

Heating cable pulling tips:

- ◆ Use a reel holder that pays out smoothly with little tension.
  - ◆ Keep heating cable strung loosely but close to the pipe being traced to avoid interference with supports and equipment.
  - ◆ Pay out designed length and mark (i.e. with fixing tape) on cable while still on reel.
  - ◆ Leave the appropriate amount of heating cable at all power connection, splice, tee and end seal locations. (Refer to component installation instructions)
  - ◇ Add additional heating cable to trace the fittings and supports or for spiralling as required by the design specifications.
  - ◆ Protect all heating cable ends from moisture, contamination and mechanical damage or other interference if left exposed before component installation.
-

---

## 3.4

### Heating cable attachment recommendations

- ▶ The heating cable may be installed straight, spiralled or in multiple runs as required by the design specification.
- ◊ **Do not** use metal attachments, vinyl electrical tape or duct tape as heating cable damage may result.
- ▶ Fix in place with a minimum of two wraps the appropriate self-adhesive glass cloth tape (see figure 1) or plastic cable ties at 300 mm intervals and additionally where necessary.
- ▶ Plastic cable ties must have a temperature rating that matches the system exposure temperature.
- ▶ The heating cable's minimum bend radius must not be exceeded (refer to p. 2)
- ▶ The heating cable's minimum spacing between turns must not be exceeded (refer to p. 2)

---

### 3.4.1

#### Straight tracing

- ▶ Straight trace the pipe unless the design calls for spiralling (see 3.4.2).
- ▶ On horizontal pipes fix on lower quadrant as shown in Figure 1 and not on bottom of pipe.
- ▶ To prevent overheating, be sure the location of the heating cable is planned so that the active heating zone will not extend into the component. Read the kit installation instructions and plan the component location before permanently attaching the cable to the pipe.
- ▶ Ensure that the active heating zones are located where heat is required i.e. on the pipe.
- ▶ Thermally insulate and weatherproof to specification.
- ▶ When installing Raychem constant wattage parallel circuit heating cables ensure that they do not overlap or cross.

**Figure 1**

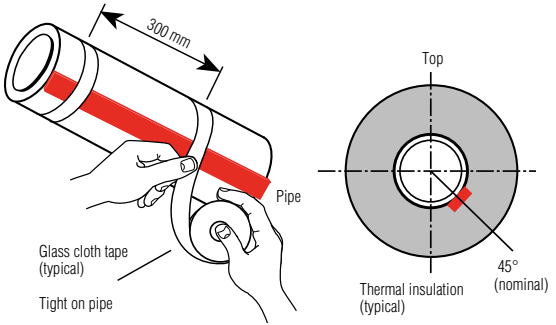

**Raychem Attachment tapes:**

- GT66 Self-adhesive glass cloth tape  
General purpose tape.
- GS54 Self-adhesive glass cloth tape  
Recommended for use on stainless-steel and cupra-nickel surfaces and high temperature applications.

**Figure 2**

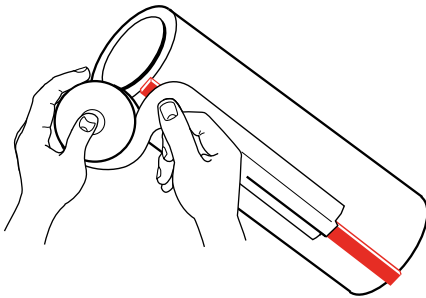

- ATE-180 Aluminium tape  
Use only if the design requires it.

### 3.4.2 Spiral tracing

- ▶ Alternative spiralling methods are shown in Figures 2a and 2b.
- ▶ Only spiral heating cable on pipe when called for by design.
- ▶ To prevent overheating, be sure the location of the heating cable is planned so that the active heating zone will not extend into the component. Read the kit installation instructions and plan the component location before permanently attaching the cable to the pipe.
- ▶ Ensure that the active heating zones are located where heat is required i.e. on the pipe.

#### Spiral Pitch Table (mm).

NB (mm)	NPS (inches)	Spiral Ratio - Metres of cable per metre of pipe				
		1.1	1.2	1.3	1.4	1.5
25	1	250	170	140	110	100
32	1¼	310	210	170	140	130
40	1½	350	240	190	160	140
50	2	430	300	240	200	180
65	2½	520	360	290	240	210
80	3	630	430	350	290	260
90	3½	720	490	390	330	290
100	4	800	560	440	370	330
125	5	990	680	550	460	400
150	6	1180	810	650	550	480
200	8	1520	1050	840	710	620

**Example:** For pipe of 80 mm NB (3" NPS) requiring 1.3 metres of heating cable per metre of pipe, pitch is 350 mm.

- ▶ Thermally insulate and weatherproof to specifications.
- ▶ When installing Raychem constant wattage parallel circuit heating cables ensure that they do not overlap or cross.

**Figure 2a**

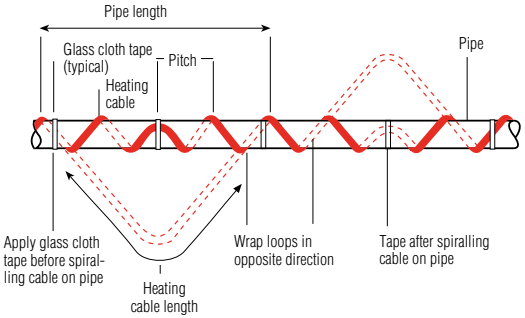

Heating cable length = pipe length x spiral ratio  
Refer to design specification for spiral ratio

- Step 1 Make starting loop as shown
- Step 2 Grasp loop and wind around pipe
- Step 3 Space evenly and attach to pipe  
Thermally insulate and weatherproof to specification

**Figure 2b**

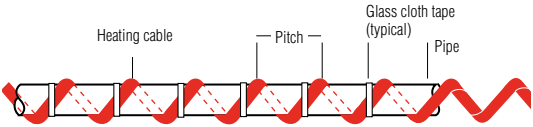

Refer to design specification for spiral pitch

Mark the pipe at the spiral pitch or use a simple length gauge

Fix the heating cable as installation progresses  
Thermally insulate and weatherproof to specification

**3.5 Cutting the heating cable**

- ▶ Cut the heating cable to length after it is attached to the pipe.  
Before cutting it, confirm the tracing allowance as per Sections 3.3 and 3.6.

### 3.6 Typical installation details

- ◆ Typical installation details for fixing heating cable to pipe fittings are shown hereafter.

#### General notes:

- ◆ Trace pipe fittings as shown to allow easy maintenance.
- ◆ Consult the design specification for the tracing requirements for fittings and supports.
- ◆ Follow the recommendations for cutting and stripping heating cables; they are included in the component installation instructions.

#### 3.6.1 Valve

Figure 3

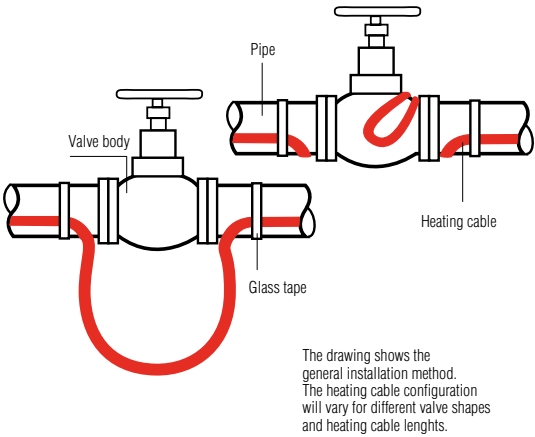

- ◆ Refer to design specification for additional heating cable length.
- ◆ Fix with self-adhesive glass cloth tape.
- ◆ Thermally insulate and weatherproof to specification (including valve stem).
- ◆ **No overlapping or crossing of the heating cable.**

### 3.6.2

### Elbow

Figure 4

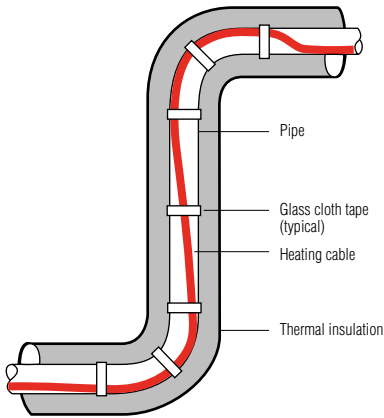

- ▶ Fix heating cable to outside (long) radius of elbow
- ▶ Fix with self-adhesive glass cloth tape
- ▶ Thermally insulate and weatherproof to specification
- ▶ **No overlapping or crossing of the heating cable.**

### 3.6.3

### Flange

Figure 5

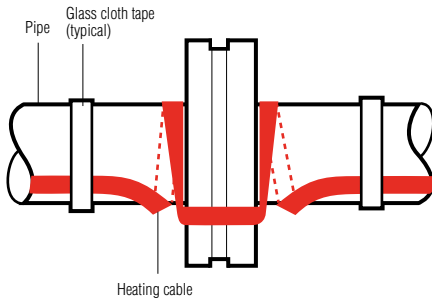

- ▶ Additional heating cable is 2 times diameter of pipe
- ▶ Fix with self-adhesive glass cloth pipe
- ▶ Thermally insulate and weatherproof to specification
- ▶ **No overlapping or crossing of the heating cable.**

---

### 3.6.4 Pipe bar hanger

---

Figure 6

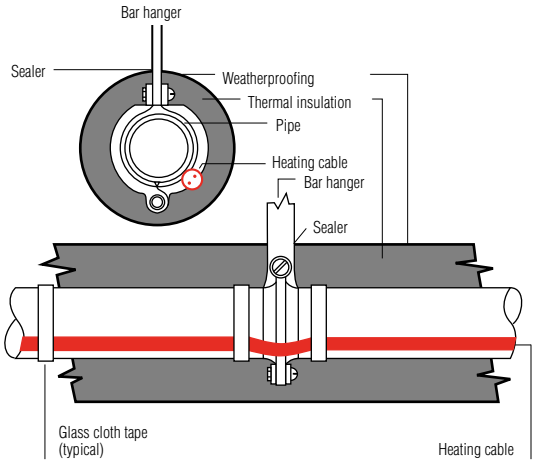

- ◇ **Do not** clamp heating cable with support. Heating cable must be over the support
  - ◆ No additional heating cable is required for bar or rod pipe hangers unless called for in the design specification, then use loop length specified
  - ◆ Fix with self-adhesive glass cloth tape
  - ◆ Thermally insulate and weatherproof to specification
  - ◆ **No overlapping or crossing of the heating cable.**
-

---

### 3.6.5 Pipe support shoe

---

Figure 7

#### Side view

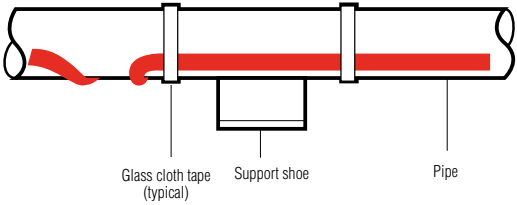

#### View from under

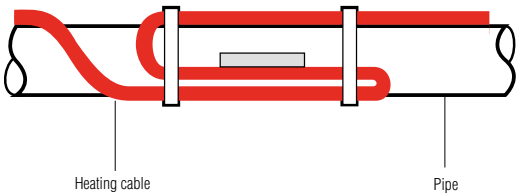

- ◆ Refer to design specification for additional heating cable length
  - ◆ Fix with self-adhesive glass cloth tape
  - ◆ Thermally insulate and weatherproof to specification
  - ◆ **No overlapping or crossing of the heating cable.**
-

---

# 4

## Components installation

---

### General notes:

Use the Design Specification to select required components.

Raychem component kits (including power connections, splices and end seals) must be used to satisfy Standards and Approval Body requirements.

Installation instructions included in the kit must be followed, including those for preparation of the heating cable conductors for connections. Before assembly, use the guide given in the instructions to ensure that the kit is correct for the heating cable and environment.

- ◇ Raychem constant wattage parallel circuit heating cables are parallel circuit design. **Do not** twist the conductors together as this will result in a short circuit.

---

### 4.1 Components required

- ◆ For the installation of all components refer to the relevant component installation instructions.
- ◆ Required for each heating cable run:  
Power connection and insulation entry kit  
End seal.
- ◆ As required:  
Accessories (pipe straps, fixing tape, support brackets, labels, etc)

---

### 4.2 Component installation hints

- ◆ On horizontal pipes locate junction boxes below pipe wherever possible.
- ◆ Locate junction boxes for easy access but not exposed to mechanical abuse.
- ◆ Position junction boxes so that power cable and heating cable entries do not point upwards.
- ◆ Fix lids in place where access not required.
- ◆ Confirm junction box stopping plugs are correct for application and fixed firmly in place.

- ▶ Route heating cable from junction box to insulation entry so as to avoid possible mechanical damage.
- ◊ **Do not** strain heating cable as it exits/enters junction boxes and insulation entries.
- ▶ Ensure heating cable is fixed above pipe straps such as used for junction box support brackets.
- ▶ Fix all low profile components in place with self-adhesive glass cloth tape.

### 4.3 Typical Installations

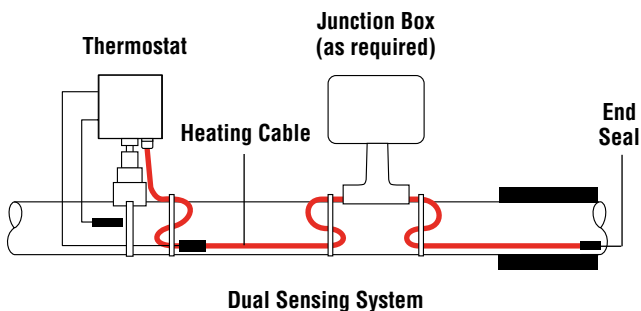
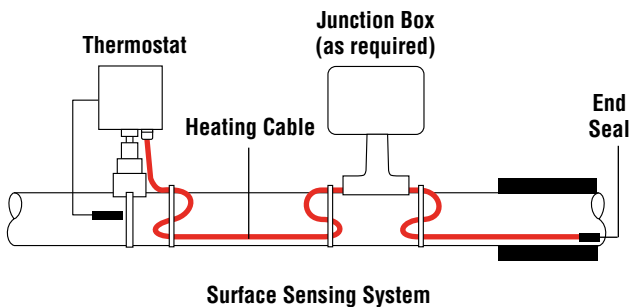
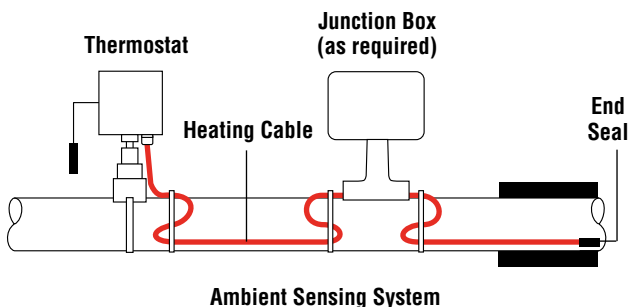

# 5

## Thermostats

---

- ▶ Raychem constant wattage parallel circuit heating cables are constant power output tracers and as such ALWAYS require temperature control.
  - ▶ The FMT and FHT range of heating cables may be used in an electric surface heating system in a hazardous area that meets the requirements of a stabilised design within the constraints of the certification.  
If a stabilised design cannot be achieved, then a thermostat control with a limiter that complies with the appropriate requirements shall be used. The limiter shall be set to ensure that the maximum temperature of the surface to be heated does not exceed that specified in the certification for a given output in a specific temperature classification.
  - ▶ ALWAYS install the correct and suitably approved thermostat as detailed in the design specification.
  - ▶ Follow the installation instructions supplied with the thermostat. Use the proper wiring diagram for the heating cable layout and control method desired.
-

# 6

## Thermal insulation and marking

---

### 6.1 Pre-insulation checks

- ▶ Visually inspect the heating cable and components for correct installation and damage. (See Section 10 if damaged.)
  - ▶ Insulation resistance (Megger) testing (as per Section 8) is recommended prior to covering the pipe with thermal insulation.
- 

### 6.2 Insulation installation hints

- ▶ Correct temperature maintenance requires properly installed and dry thermal insulation.
  - ▶ Thermally insulate and weatherproof to design specification.
  - ▶ Check insulation type and thickness against the design specification.
  - ▶ To minimize potential heating cable damage, insulate as soon as possible after tracing.
  - ▶ Check that all pipework, including fittings, wall penetrations and other areas, has been completely insulated.
  - ▶ Ensure that heating cable is not damaged during installation of cladding for example by drills, self tapping screws and sharp edges of cladding.
  - ▶ Check that all insulation entry kits are fitted correctly and sealed.
  - ▶ Ensure that all places where valve stems, support brackets, thermostat capillaries, etc exit the cladding are sealed.
-

---

## 6.3

### Marking

- ▶ Install warning labels along piping at suitable intervals (3 m intervals recommended) on alternate sides as a warning.
  - ▶ Mark on outside of insulation the location of heating cable components.
-

# 7

## Power supply and electrical protection

---

### 7.1 Electrical loading

Size overcurrent protective devices according to the design specification.

---

### 7.2 Residual current (earth fault) protection

Tyco Thermal Controls insists on the use of a 30 mA residual current device to provide maximum safety and protection. However, where there is a marked increase in nuisance tripping, a maximum 300 mA residual current device may be used.

For heating cables installed in a hazardous area, the use of residual current devices is normally a condition of their approval.

# 8

## Heating cable testing

---

### 8.1 Recommendations

Tyco Thermal Controls recommends an insulation resistance test before installing heating cable; before installing thermal insulation; prior to initial start-up; and as part of the periodic maintenance. (see Section 9.2).

---

### 8.2 Test method

After completing heating cable installation, the insulation resistance between the conductors and the braid or metal pipe should be checked (see Section 6.1) using a 2500 VDC megger™. Minimum readings should be 10 Megohms regardless of the heating cable length. The installer should record the original values for each circuit on the installation record sheet (see page 23).

---

**Figure 4**

Test A: Test between heating cable and braid

Test B: Test between heating cable braid and pipe

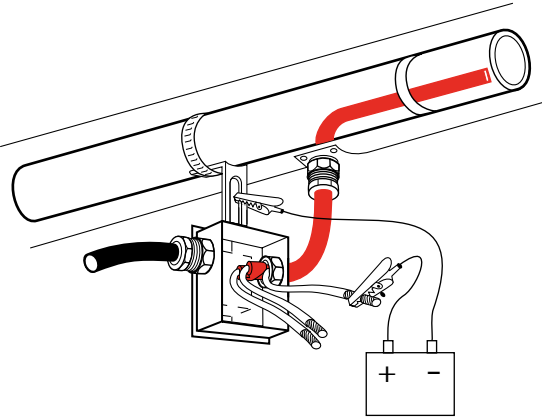
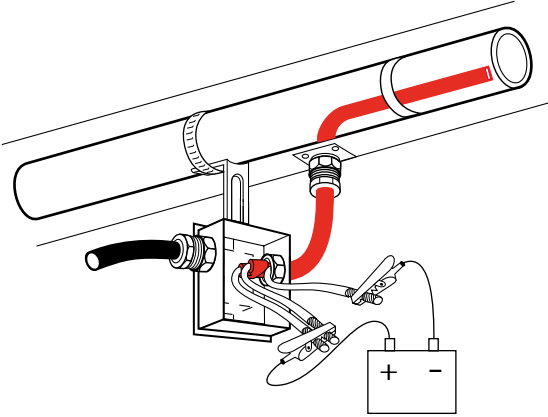



# Operation, maintenance and pipe repairs

---

## 9.1 Heating cable operation

- ◆ **Temperature exposure must not exceed that specified in the product literature. Exceeding those limitations will shorten the service life and may permanently damage the heating cable.**
  - ◆ Pipe insulation must be complete and dry to maintain the correct temperature.
- 

## 9.2 Inspection and maintenance

- ◆ Visual inspection: Exposed heating cable and pipe insulation should be checked periodically to make sure that no physical damage has occurred.
  - ◆ Meggering: The system should be meggered regularly. When meggering the insulation resistance from the main supply panel, it is recommended that the test is performed between L/N (together) and PE. Freeze protection systems should be meggered before the winter months each year (see section 8). Temperature maintenance systems should be tested at least twice a year. Function testing of electrical protection and temperature control systems should be carried out at regular intervals.
  - ◆ The Periodic Inspection Record on the following pages should be filled out during maintenance of each circuit in your system.
- 

## 9.3 Piping systems repair and maintenance

- ◆ Isolate heating cable circuit and protect the heating cable from mechanical or thermal damage during pipe repair work.
  - ◆ Check heating cable installation after pipe repairs and restore thermal insulation following the recommendations in Section 6. Check correct functioning of electrical protection systems.
-

# 10 Heating cable damage

---

- ⚠ **Do not repair damaged heating cable.**  
Remove entire damaged section and splice in a new length using the appropriate Raychem components.
- ⚠ **Replace damaged heating cable at once.**  
Damage allowing moisture and contamination to enter the heating cable may result in arcing earth faults and potential fire hazards.
- ⚠ Heating cable exposed to fire or flame may cause further fire damage if powered.  
Remove from service at once and replace before re-use.

# 11 Troubleshooting guide

---

Refer to the Troubleshooting guide on pages 26-29. If the problem persists after following the guide procedures, contact your Tyco Thermal Controls representative immediately.

---

## INSTALLATION RECORD SHEET

25

CIRCUIT NO.									
INSTALLATION RECORDS FOR: _____									
Circuit breaker number									
Drawing reference number									
Megger test on pipe before insulating (bypass thermostat if applicable).	Reading								
	Initial Date								
Megger test after insulating (bypass thermostat if applicable).	Reading								
	Initial Date								
Circuit voltage	Panel								
	Connection terminals								
Insulation completed and sealed	Initial								
	Date								
Locations of low profile components are marked on the cladding.	Initial								
	Date								

26

REMARKS & COMMENTS:

## INSPECTION AND MAINTENANCE RECORD SHEET

27

CIRCUIT NO.									
		MONTH _____				YR. _____			
No signs of overheating, moisture, or corrosion, etc.	Initial								
	Date								
In connection systems Heating cable and cable glands tight Connection terminals tight Earth connection tight Insulation in good condition	Initial								
	Date								
Thermostats set properly and capillaries are protected	Initial								
	Date								
Megger test (bypass thermostat if applicable)	Reading								
	Initial Date								
Circuit voltage	Panel								
	Connection terminals								
All boxes and thermostats have been firmly closed	Initial								
	Date								
Locations of under insulation components are marked on the insulation lagging	Initial								
	Date								

REMARKS & COMMENTS

# Troubleshooting guide

---

**A**

**Symptom:** Overcurrent protection trips or blows.

**Probable Causes**

**Corrective Actions**

---

- |  |  |
|--|--|
| <b>1</b> Electrical fault at:<br><b>a</b> damaged heating cable<br><b>b</b> faulty splices or tees<br><b>c</b> end seal<br><b>d</b> connection | <b>1</b> Investigate and remedy (see note 1):  |
| <b>2</b> Circuit oversized   | <b>2</b> Resize or redesign  |
| <b>3</b> Start-up below design temperature   | <b>3</b> <b>a</b> redesign for lower start-up temperatures.<br><b>b</b> preheat pipe from alternative heat source to within exposure temperatures given in Product Data Sheets.<br><b>c</b> Energize part of circuit followed by remainder (e.g. in sequence.) |
| <b>4</b> Defective electrical protection   | <b>4</b> Replace.  |
- 

**B**

**Symptom:** RCD trips.

**Probable Causes**

**Corrective Actions**

---

- |   |  |
|---|--|
| <b>1</b> Earth fault at:<br><b>a</b> damaged heating cable<br><b>b</b> faulty splices or tees<br><b>c</b> end seal<br><b>d</b> connection | <b>1</b> Investigate and remedy (see note 1):  |
| <b>2</b> Excessive moisture in:<br><b>a</b> junction boxes<br><b>b</b> splices and tees<br><b>c</b> end seals                             | <b>2</b> Dry out and reseal or remake immediately. Perform insulation resistance test. (10 M $\Omega$ minimum) |
| <b>3</b> High leakage currents due to a combination of excessive lengths of power cable and heating cable.                                | <b>3</b> Redesign  |
| <b>4</b> Mains borne disturbances   | <b>4</b> Redesign distribution, guidance is available from Raychem   |
| <b>5</b> Defective RCD  | <b>5</b> Replace.  |
-

**C****Symptom:** No power output.**Probable Causes****Corrective Actions**

- |   |  |
|---|--|
| <b>1</b> Loss of supply voltage due to:<br><b>a</b> overcurrent or residual current protection operating<br><b>b</b> loose terminals in junction box<br><b>c</b> loss of supply cable continuity (e.g., open circuited from damage) | <b>1</b> Restore supply voltage<br><b>a</b> following A and B (page 26)<br><b>b</b> re-tighten terminals<br>NB: If excessive heating has occurred due to high resistance, replace terminals or crimps<br><b>c</b> locate damage and repair |
| <b>2</b> Control thermostat is connected in the normally open position or limit thermostat is tripped   | <b>2</b> Reconnect to normally closed position   |
| <b>3</b> High resistance connection at:<br><b>a</b> junction box terminals<br><b>b</b> splices and tees   | <b>3</b> Locate and remedy by:<br><b>a</b> retighten<br><b>b</b> repair<br>NB: If excessive heating has occurred due to high resistance, replace terminals or crimps   |

**D****Symptom:** Low pipe temperature.**Probable Causes****Corrective Actions**

- |  |   |
|--|---|
| <b>1</b> Wet thermal insulation  | <b>1</b> Remove and replace with dry insulation of correct specification and ensure complete weatherproofing              |
| <b>2</b> Design error  | <b>2</b> <b>a</b> check with competent authority for design conditions<br><b>b</b> modify to meet Raychem recommendations |
| <b>3</b> Incorrect setting or operation of controls e.g., thermostats. | <b>3</b> Repair or reset to correct level of operation  |

**Note:**

Locate faults by the following steps:

- 1 Visually inspect the power connections, splices and end seals for correct installation.
- 2 Look for signs of damage at:
  - a) Valves, pumps, flanges and supports.
  - b) Areas where repairs or maintenance work has been carried out.
- 3 Look for crushed or damaged insulation and cladding along the pipe.
- 4 If after 1, 2 and 3 above the fault has not been located, then either:
  - a) Consult Tyco Thermal Controls for further assistance.
  - b) Where local practices and conditions allow (e.g., non hazardous areas) isolate one section of heating cable from another by cutting in half and testing (e.g., Insulation Resistance) both halves until general area of damage is found.  
Remove insulation and expose fault.

Raychem is a trademark of Tyco Thermal Controls, LLC or it's affiliates.

All of the above information, including illustrations, is believed to be reliable. Users however, should independently evaluate the suitability of each product for their application. Tyco Thermal Controls makes no warranties as to the accuracy or completeness of the information and disclaims any liability regarding its use. Tyco Thermal Controls's only obligations are those in the Standard Terms and Conditions of Sale for this product and in no case will Tyco Thermal Controls be liable for any incidental, indirect or consequential damages arising from the sale, resale, use or misuse of the product. Tyco Thermal Controls Specifications are subject to change without notice. In addition Tyco Thermal Controls reserves the right to make changes in materials or processing, without notification to the Buyer, which do not affect compliance with any applicable specification.

#### **België / Belgique**

Tyco Thermal Controls  
Romeinse Straat 14  
3001 Leuven  
Tel.+32 16 213 502  
Fax +32 16 213 604

#### **Bulgaria**

ERZET Engineering  
Kompl. Bratja Miladinovi/b157/vch.4A  
BG-8000 Burgas  
Tel./fax +359 56 3 4198  
Mobile +359 88 639 903  
Fax (UK) +44 8701368787

#### **Česká Republika**

Raychem HTS s.r.o.  
Pražská 636  
252 41 Dolní Břežany  
Tel. +420 241 009 215  
Fax +420 241 009 219

#### **Danmark**

Tyco Thermal Controls Nordic AB  
Flöjelbergsgatan 20B  
SE-431 37 Mölndal  
Sweden  
Tel. +46 70 11 04 00  
Fax +46 70 11 04 01

#### **Deutschland**

Tyco Thermal Controls GmbH  
Birlenbacher Strasse 19-21  
57078 Siegen-Geisweid  
Tel. 0800 1818205  
Fax 0800 1818204

#### **España**

Tyco Thermal Controls N.V.  
Ctra. De la Coruña, km. 23,500  
Edificio ECU I  
28290 Las Rozas, Madrid  
Tel. +34 902 125 307  
Fax +34 91 640 29 90

#### **France**

Tyco Thermal Controls SAS  
B.P. 90738  
95004 Cergy-Pontoise Cedex  
Tél. 0800 906045  
Fax 0800 906003

#### **Hrvatska**

ELGRI d.o.o.  
S. Mihalica 2  
10000 Zagreb  
Tel. +385 1 6050188  
Fax +385 1 6050187

#### **Italia**

Tyco Thermal Controls SPA  
Centro Direzionale Milanofiori  
Palazzo F1  
20090 Assago, Milano  
Tel. +39 02 57761520  
Fax +39 02 57761528

#### **Lietuva/Latvija/Eesti**

Tyco Thermal Controls BV  
Atstovybe  
Smolensko g. 6  
LT-03201 Vilnius  
Tel. +370 5 2136633  
Fax +370 5 2330084

#### **Magyarország**

Szarka Ignác  
Maroshévíz u. 8  
1173 Budapest  
Tel. +36 1 253 76 17  
Fax +36 1 253 76 18

#### **Nederland**

Tyco Thermal Controls b.v.  
Van Heuven Goedhartlaan 121  
1181 KK Amstelveen  
Tel. 0800 0224978  
Fax 0800 0224993

#### **Norge**

Tyco Thermal Controls Norway AS  
Postboks 146  
1441 Drøbak  
Tel. +47 66 81 79 90  
Fax +47 66 80 83 92

#### **Österreich**

Tyco Thermal Controls  
Office Wien  
Brown-Boveri Strasse 6/14  
2351 Wiener Neudorf  
Tel. +43 2236 86 00 77  
Fax +43 0036 86 00 77-5

#### **Polska**

Tyco Thermal Controls Polska Sp. z o.o.  
ul. Cybernetyki 19  
02-677 Warszawa  
Tel. 0 800 800 114  
Fax 0 800 800 115

#### **Republic of Kazakhstan**

Tyco Thermal Controls  
4 "a", Smagulova St.  
Atyrau, 060005  
Tel. +7 7122 325554  
Fax +7 7122 586017

#### **Romania**

Tyco Thermal Controls Romania  
Strada Sinaii nr 3  
100357 Ploiesti, Prahova  
Tel. +40 34 480 21 44  
Fax +40 34 480 21 41

#### **РОССИЯ и другие страны СНГ**

ООО «Тайко Термал Контролс»  
Россия 141407 Московская область,  
г. Химки, ул. Панфилова, д. 19, стр. 1  
Д/Ц «Нантри Парк», 11 этаж  
Тел: + 7 495 926 1885  
Факс: + 7 495 926 1886

#### **Schweiz / Suisse**

Tyco Thermal Controls N.V.  
Office Baar  
Haldenstrasse 5  
Postfach 2724  
6342 Baar  
Tel. +41 41 766 30 80  
Fax +41 41 766 30 81

#### **Serbia**

Keying d.o.o.  
Vuka Karadžića 79  
23300 Kikinda  
Tel. (230) 401 770  
Fax (230) 401 790

#### **Suomi**

Tyco Thermal Controls Nordic AB  
Flöjelbergsgatan 20B  
SE-431 37 Mölndal  
Sweden  
Tel. 0800 11 67 99  
Fax 0800 11 86 74

#### **Sverige**

Tyco Thermal Controls Nordic AB  
Flöjelbergsgatan 20B  
SE-431 37 Mölndal  
Tel. +46 31 3355800  
Fax +46 31 3355899

#### **Türkiye**

SAMM DIS TICARET A.S.  
Yeniyl Sk.  
Etab Is Merkezi C Blok Kat:6 34722  
Acibadem/Kadıköy  
Istanbul  
Tel. +90 216 3256162213  
Mobile +90 533 7790662  
Fax +90 216 3252224

#### **United Kingdom**

Tyco Thermal Controls (UK) Ltd  
3 Rutherford Road,  
Stephenson Industrial Estate  
Washington, Tyne & Wear  
NE37 3HX  
Tel. 0800 969013  
Fax 0800 968624

**tyco**

Thermal Controls

www.tycothermal.com