

Raychem

HWAT-Plus™ System

INSTALLATION

AND OPERATION

MANUAL

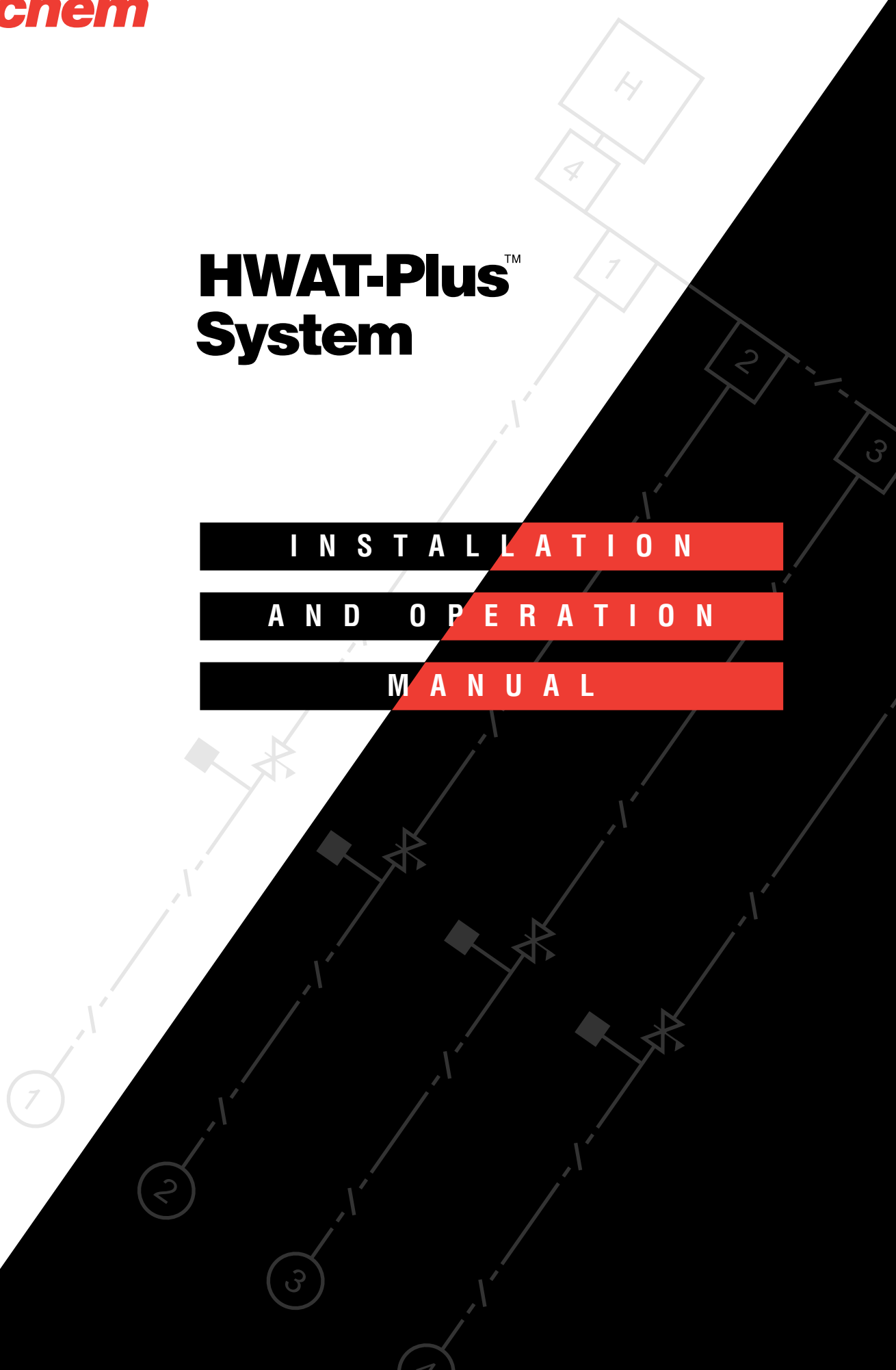

Contents

	Introduction	5
--	--------------	---

1. HWAT-Plus products	Self-Regulating Heating Cables	6
	Components	6
	Accessories	6
	Heating Cable and Component Storage	7
	Tools Required	7
	Heating Cable Construction	8

2. System design	Water Temperature Maintenance	9
	Circuit Location	9
	Typical System Installation	10
	Heating Cable Specification	11
	Insulation	12
	Electrical Requirements	13

3. System testing	Required Testing	14
	Order of Testing	14
	Insulation Resistance Testing (Megger Test)	14
	Short-Circuit Testing and Continuity Testing	15
	Visual Inspection	16
	Troubleshooting Guide	16

4. System operation	System Start-up	19
	Normal Operation	19
	Periodic Inspection	19
	Installation Testing Record	20
	HWAT-Plus Circuit Schedule	21
	Power Connection Location Schedule	22
	Periodic Inspection Record	23

5. Installation responsibilities	Instructions	25
	Trade Coordination	26
	General Contractor or Construction Manager	27
	Plumbing Contractor	29
	Installing Contractor	31
	Insulation Contractor	36
	Electrical Contractor	37
	Sheetrock® Contractor	39

Introduction

This manual presents Raychem's recommendations for installing, testing, and operating an HWAT-Plus system on insulated indoor metallic hot water piping.

⚠ WARNING: FOLLOW THESE INSTALLATION AND OPERATION INSTRUCTIONS CAREFULLY. IMPROPER INSTALLATION OR DAMAGE TO THE HWAT-PLUS SYSTEM COULD CAUSE SUSTAINED ARCING OR FIRE. TO MINIMIZE THE DANGER OF FIRE IF THE HEATING CABLE IS DAMAGED OR IMPROPERLY INSTALLED, USE A GROUND FAULT PROTECTION DEVICE. ELECTRICAL FAULT CURRENTS MAY BE INSUFFICIENT TO TRIP A CONVENTIONAL CIRCUIT BREAKER. OBSERVE THE WARNINGS HIGHLIGHTED WITH THE SYMBOL ⚠ IN THIS MANUAL.

By following these guidelines you will have a reliable, energy-efficient system. For information regarding other heat-tracing applications, contact your Raychem representative.

How to Use This Book

This manual is designed to provide instructions to all trades involved in the installation of an HWAT-Plus system.

Soon after the site work and foundation are completed, the general contractor or construction manager should arrange a meeting with the other trades and the Raychem representative.

At this meeting, each trade should be given the section of this manual appropriate to that trade and any questions regarding coordination and timing should be addressed.

As the HWAT-Plus installation is completed, the testing and circuit schedules in Chapter 4 should be filled in and returned to the general contractor or construction manager.

The remainder of this manual provides general heating cable information, a design guide, troubleshooting and testing procedures, and circuit schedules.

At the end of construction, the owner should be given the manual to serve as a reference and a log for periodic inspections.

When your HWAT-Plus system is installed and periodically checked in accordance with this manual, you will have a superior water temperature maintenance system that operates without noise or balancing problems.

System Description

The HWAT-Plus system provides temperature maintenance of domestic hot water lines by tracing the main supply lines with the HWAT-Plus heating cable. This electric heating cable replaces the small amount of heat that pipes lose to the environment through the thermal insulation. No thermostats are needed with the HWAT-Plus system because the heating cable compensates for temperature variations. By changing its power output in response to the pipe temperature, the HWAT-Plus heating cable will produce more power where needed and compensate for temperature differences.

Codes

The installation of the HWAT-Plus system is governed by Section 427 of the National Electrical Code and the Canadian Electrical Code, Part II, C22.2 No.130-M1985. Your installation must comply with applicable codes and standards in your area.

Important

The instructions in this manual and in the product packages must be followed. The Raychem warranty will not apply in the event of damage caused by accident, misuse, neglect, alteration, improper installation, repair, or testing.

1. HWAT-Plus products

Self-Regulating Heating Cables

The HWAT-Plus heating cables are traced along the hot water supply pipes to keep the water hot during periods of low usage. These heating cables respond to the local pipe temperature and increase their heat output when temperatures drop and decrease their heat output when temperatures rise. The result is a “self-regulating” heater with a power-temperature characteristic as shown. These heating cables can not overheat themselves, even if overlapped, and do not require the use of thermostats. The illustration on page 8 further explains the cable construction.

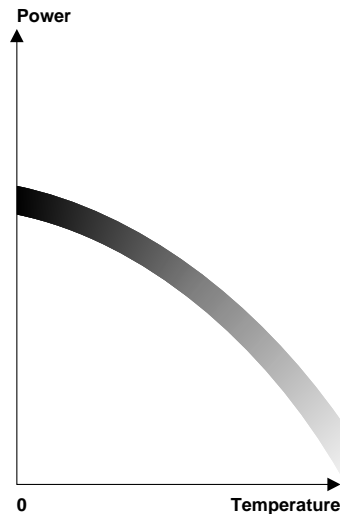

*Self-regulating characteristic of
HWAT-Plus heating cables*

Components

Raychem HWAT-Plus components must be used to satisfy code and approval agency requirements. Installation instructions included with the kits and in Section 5 must be followed. The components (and catalog numbers) for use with the HWAT-Plus system are:

- **Power connection kit (HWK-XP)**
- **End seal kit (HWK-XE)**
- **Splice kit (HWK-XS)**
- **Tee kit (HWK-XT)**

Accessories

In addition to the heating cable and components, the HWAT-Plus system requires:

- **“Electric Traced” Labels (ETL)**
- **GT-66 Glass Tape (GT-66)**

These Raychem parts may be ordered through your Raychem representative.

⚠ To minimize the danger of fire if the heating cable is damaged or improperly installed, use a ground fault protection device with a nominal 30 mA trip level. Electrical fault currents may be insufficient to trip a conventional circuit breaker.

Thermostats should not be used with the HWAT-Plus System unless required by Raychem. A timer may be used to control the system if the building will not be used evenings or on weekends.

Heating Cable and Component Storage

To prevent damage to the HWAT-Plus system before installation, the following precautions should be observed:

1. Store the heating cable in a clean dry place at 0°F to 100°F.
2. Protect the heating cable and components from mechanical damage. Keep them out of high traffic areas where they may be walked on or accidentally damaged.

Tools Required

Installation of the HWAT-Plus heating cable and components will not require special tools. Following are lists of the ordinary tools you will need to perform the various installation tasks. HWAT-Plus component instructions include a more detailed description of the tools required to assemble each kit.

Stripping HWAT-Plus heating cable:

- Utility knife
- Diagonal cutters
- Pliers (long nosed)

Cutting HWAT-Plus heating cable:

- Cable cutters

Assembling splices & tees:

- All tools listed above
- Appropriate crimp tool
- Screwdriver (flat blade)

Assembling power connection:

- All tools listed above
- Propane torch or heat gun

Testing heating cable:

- 2500 Vdc Megohmmeter (Megger)
- Battery
- Voltmeter

Heating Cable Construction

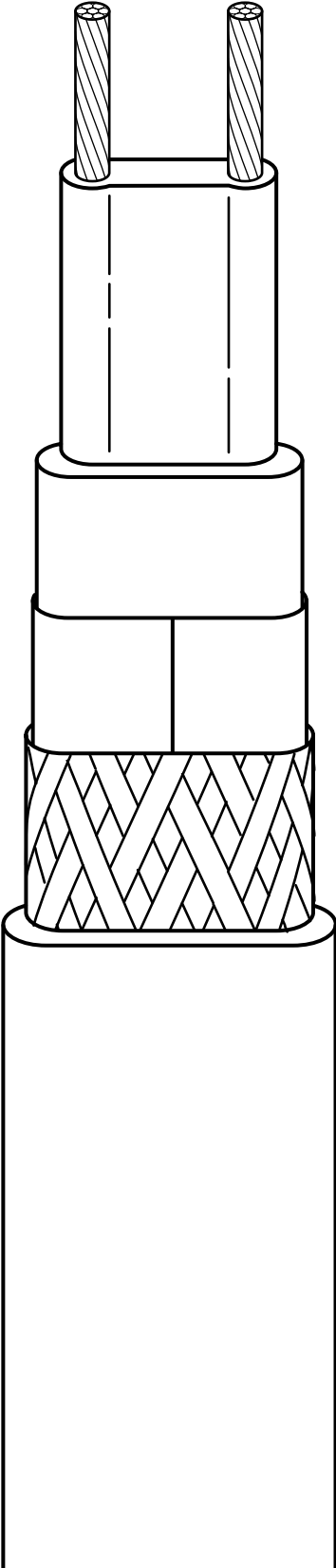

Copper bus wires: The nickel-plated copper bus wires are not heating elements; they serve as the voltage source for the heating cable by carrying current down their entire length.

Conductive core: The black conductive core covers the copper conductors and forms a web between them. This is the heating element; it generates heat by allowing electric current to pass through it. This material is electrically conductive; do not treat it as an insulator.

Heating cable insulating jacket: The heating cable insulating jacket is an electrical insulator. This jacket is blue or black for HWAT-Plus.

Foil wrap: The foil wrap provides mechanical and chemical protection.

Tinned-copper braid: The primary purpose of the braid is to provide a ground path, as required by electrical codes and approval agencies. The braid also provides resistance to damage from physical abuse.

Outer jacket: The outer jacket provides mechanical protection from damage and physical abuse. Printed on this insulating jacket is the name of the heating cable, the manufacturing batch number, and other information. The jackets are color coded for easier product identification:

- HWAT-B2 is blue.
- HWAT-G2 is green.
- HWAT-Y2 is yellow.
- HWAT-R2 is red.

2. System design

For complete design information consult the HWAT-Plus System Design Guide.

Water Temperature Maintenance

The HWAT-Plus system provides temperature maintenance of hot water lines without recirculation. This is accomplished by tracing the main supply lines with the HWAT-Plus heating cable, an electric heating cable that automatically compensates for temperature variations without the use of a thermostat. Because the heating cable gradually changes its power output in response to temperature, it compensates for temperature differences by minimizing them; it does not completely eliminate temperature variations.

Water temperature is primarily a function of the temperature at which it leaves the water heater, storage tank, or mixing valve. For example, during periods of high usage the hot water flow is great enough that the HWAT-Plus system will have very little effect on the water temperature. And during periods of low usage (10:00 p.m. to 6:00 a.m.) the temperature of the water in the supply pipes is dependent on the HWAT-Plus system. During these periods, the water temperature depends on:

- ambient air temperature
- insulation type and thickness
- pipe size and material
- voltage applied to HWAT-Plus heating cable

Consult your Raychem representative if your insulation, air temperature around the pipe, pipe material, maintenance temperature, or voltage are different from those shown in pages 11 through 13 of this manual.

Circuit Location

Placement of power connections and circuit routing is an important part of the HWAT-Plus system design, and one that requires coordination between the plumbing and electrical designers. Proper design must consider:

- maximum circuit lengths for the product
- proximity of electrical distribution panels
- accessibility of power connection locations
- size of circuit breakers provided
- length and location of branches

A few general rules:

1. HWAT-Plus circuits should divide the plumbing into logical segments.

- For a high-rise building with long risers, it's best to have each riser on a separate circuit with the header or main on another circuit.
- In buildings with multiple pressure zones, it may make sense to place power connections at the pressure-reducing valves.
- High-pressure and low-pressure water should be on separate circuits.
- Each wing or building in a large project should be on a separate circuit.

This separation of HWAT-Plus circuits into sections that coincide with logical plumbing separations makes trouble-shooting easier and makes the circuit layout more sensible. Small circuits may be ganged together on one circuit breaker as long as the total allowed circuit length is not exceeded.

2. Don't exceed the maximum circuit length.

Remember that the circuit lengths shown on page 13 are absolute maximums. If it is anticipated that jobsite changes may require circuit extensions, do not design circuits for this maximum length. Provide an allowance for these changes. Also be sure to include the length of any branches tee'd to the heating cable and any expected changes in the future (such as tenant work or planned expansions). Show the heating cable length on the drawing at the power connection location.

3. Show connection locations on the drawings.

For ease of identification, use symbols on page 12 to designate the HWAT-Plus power connection points, tees, and end seals.

In complex plumbing systems you may need to identify the components with the circuit number, water temperature, or electrical panel number.

4. Locate power connections near the electrical panel.

Plumbing designers should look at the electrical plans. By minimizing the distance from the circuit breaker panel to the heating cable connection, you can reduce the installed cost of the HWAT-Plus system can be reduced.

5. Locate tees in accessible areas.

For easier assembly, inspection, and trouble-shooting, it's recommended that tees be accessible.

If a tee can be located in an accessible area, it may be a logical point for a new circuit. Several circuits may be ganged together as long as the sum of the individual circuit lengths does not exceed the maximum circuit length indicated on page 13.

Typical System Installation

The illustration on page 11 shows the layout of a typical HWAT-Plus system. Power connections are used to connect the heating cable circuit to power. Splices are used where required to join two lengths of heating cable. Tees are used wherever the heating cable system branches. End seals are used at the end of every branch to terminate the circuit.

Glass tape is used to attach the cable to the pipe, and "Electric Traced" labels are placed on the insulation to indicate that the pipes are traced. Service loops are recommended as indicated to simplify maintenance of the plumbing system and removal of components.

For more information refer to the HWAT-Plus System Design Guide.

Typical System Layout

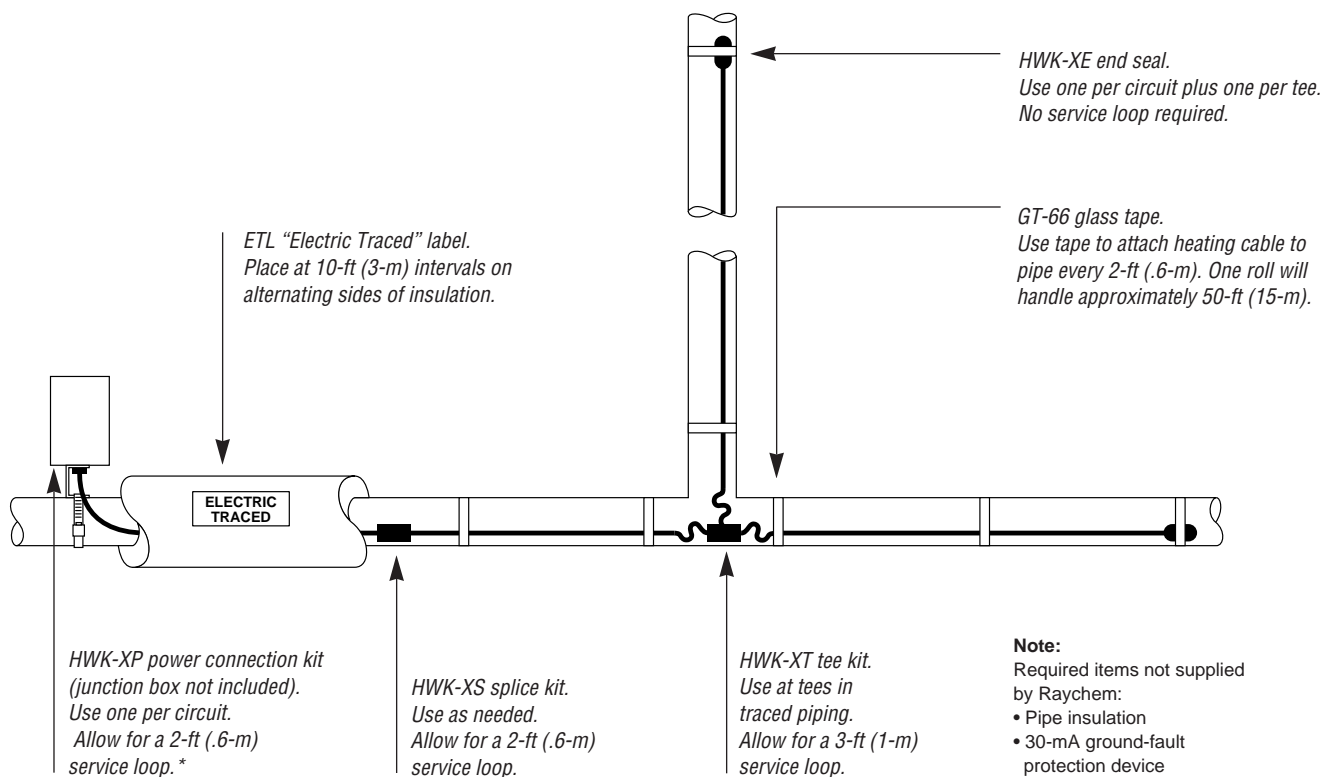

Heating Cable Selection

Each HWAT-Plus heating cable is designed to maintain a specific temperature range. Verify that the cable to be installed will provide the desired nominal temperature by checking the table below. HWAT-Plus cables are designed to maintain their indicated temperatures within a range of indoor ambient temperatures. Verify that the indoor ambient temperature will fall within the range indicated in the chart below. If not, consult your Raychem representative or Raychem at 1-800-272-9243 ext. 1512.

For more information regarding system design and cable specifications, refer to the HWAT-Plus System Design Guide and HWAT-Plus System Data Sheet.

HWAT-Plus Self-Regulating Heating Cable

Heating cable type	Nominal pipe temperature	Ambient temperature	Jacket color	Installation
HWAT-B2	105°F (40°C)	74°F–79°F(23°C–26°C)	Blue	Straight-trace, no spiraling
HWAT-G2	115°F (45°C)	70°F–78°F(21°C–26°C)	Green	Straight-trace, no spiraling
HWAT-Y2	125°F (50°C)	70°F–78°F(21°C–26°C)	Yellow	Straight-trace, no spiraling
HWAT-R2	140°F (60°C)	70°F–78°F(21°C–26°C)	Red	Straight-trace, no spiraling

Insulation

The HWAT-Plus system will only maintain the desired water temperature if the piping is insulated according to the following schedule. Use fiberglass insulation or another thermal insulation with equivalent thermal conductivity. If the insulation is expected to be different, contact your Raychem representative or Raychem at 1-800-272-9243 ext. 1512.

Insulation Schedule

Pipe size (inches)	Fiberglass insulation thickness (inches)
1/2-1	1
1 1/4-2	1 1/2
2 1/2-6	2

Plumbing Drawings

Note: For pipe sizes 1 1/4" and smaller, use insulation sized for a 1/4" larger pipe to allow room for installation over cable.

The following symbols are often used to identify the HWAT-Plus circuits (circuit numbers shown within symbol):

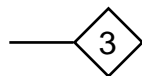

Circuit continued on another drawing

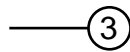

End of circuit

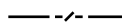

Hot water supply pipe traced with HWAT-Plus heating cable

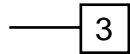

Power connection

Electrical Requirements

The HWAT-Plus system is designed to operate at 208 Vac, with 30-mA ground-fault protection devices, and with the maximum circuit lengths indicated below.

It is good engineering practice to use the smallest circuit breaker that will accommodate the installed circuit length. For example, it is recommended that all HWAT-B2 circuits be protected with a 15-A circuit breaker.

Voltage. This manual assumes that system operation is at 208 volts. For operation at other voltages, contact Raychem.

Circuit Breaker Sizing. For start-up at 60°F (26°C); maximum circuit length is indicated in the table below in feet (meters). To minimize the risk of fire from sustained electrical arcing if the heating cable is damaged or improperly installed, use a ground fault protection device with a nominal 30-mA trip level. Arcing may not be stopped by conventional circuit breakers. Suitable circuit breakers are available from Westinghouse (type QPGFEP and QBGFEP) or Square D (type QOEPD AND QOBEPD)

Circuit breaker	Ground fault protection	HWAT-B2	HWAT-G2	HWAT-Y2	HWAT-R2
30 amp	30 mA	-	800 (240)	800 (240)	500 (150)
20 amp	30 mA	-	700 (210)	500 (150)	330 (120)
15 amp	30 mA	800 (240)	520 (155)	350 (105)	250 (75)

Operating Current Draw and Transformer Sizing. The current draw below should be used for transformer sizing and energy usage estimates only; circuit breaker sizing must be based on the table above.

HWAT-B2	0.006 amp/ft @ 105°F (.020 amp/m @ 40°C)
HWAT-G2	0.008 amp/ft @ 115°F (.026 amp/m @ 45°C)
HWAT-Y2	0.010 amp/ft @ 125°F (.033 amp/m @ 50°C)
HWAT-R2	0.015 amp/ft @ 140°F (.049 amp/m @ 60°C)

3. System testing

Required Testing

To ensure the proper installation and operation of the HWAT-Plus system, three separate checks are required: insulation resistance using a megohmmeter (Megger), continuity testing using a battery, and visual inspection.

Damage to the insulating jacket of the heating cable can be detected with an insulation resistance test using a megohmmeter (Megger). Testing the heating cable at 2500 Vdc can detect damage — such as cuts, punctures, and scrapes — that create an electrical path from the conductive core to the braid. Testing at lower voltages (such as 1000 or 500 Vdc) can be useful but is not as sensitive; therefore, 2500 Vdc is recommended.

Continuity testing using a battery of 24 Vdc or less ensures that the bus wires are properly connected in a splice or tee.

Visual inspection ensures that the cable is properly attached to the pipe, the components have been installed correctly, and all required piping is traced with heating cable.

Order of Testing

Time	Test required
When the cable is received	Megger test
After heating cable and component installation, but before thermal insulation is installed	Megger test, continuity test, visual inspection
After the insulation is installed, but before the Sheetrock is installed	Megger test, visual inspection
Before the initial start-up	Megger test

Insulation Resistance Testing (Megger Test)

To test HWAT-Plus heating cables with a Megger:

1. Connect one lead from the instrument to the HWAT-Plus heating cable braid.
2. Connect the other lead to both bus wires, as shown below.

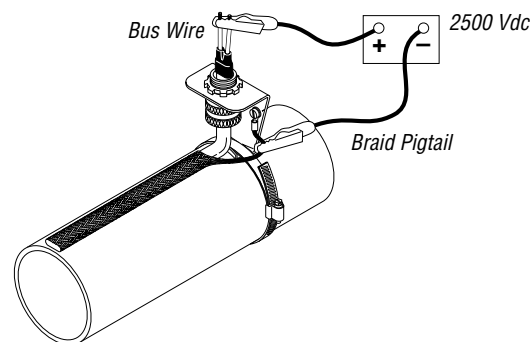

3. Apply 2500 Vdc and measure resistance. The minimum readings should be 20 megohms regardless of heating cable length.
4. If the megger reading is less than 20 megohms, locate the fault and correct or replace damaged cable.

⚠ WARNING: DAMAGED HEATING CABLE *MUST BE REPLACED*. DO NOT ENERGIZE DAMAGED HEATING CABLE. FAILURE TO REPLACE DAMAGED HEATING CABLE CAN CAUSE ARCING OR FIRE.

5. Record the original values for each circuit on the Installation Testing Record or the Periodic Inspection Record.

Short-Circuit Testing and Continuity Testing

To ensure that the bus wires are properly connected in a splice or tee, the following test must be conducted before energizing the heating cable.

1. Before attaching the end seal, strip back the core 1/2 inch to allow access to the bus wires at all cable circuit ends.
2. Using a battery, apply a voltage of 24 Vdc or less to the bus wires at the beginning of the circuit. Note: This test will draw current even if there is no short-circuit.

DO NOT APPLY LINE VOLTAGE TO THE HEATER CIRCUIT. THE HEATING CABLE CAN BE PERMANENTLY DAMAGED IF A SHORT-CIRCUIT EXISTS.

3. Check for voltage at the ends of the circuit. The voltage measured at the end of a very long circuit will be less than the applied voltage. However, if no voltage is detected, an open or short circuit is indicated.
4. If any branch of the circuit fails this test, inspect and repair as necessary any tees or splices in that section of heating cable.
5. Retest the circuit to ensure that all open and short circuits have been detected.
6. Cut a sufficient amount of cable off the ends so that the bus wires do not stick out of the core. Seal the end with an HWAT-Plus end seal.

⚠ WARNING: EXPOSED HEATER ENDS CAN CAUSE SHOCK OR FIRE. INSTALL AN HWAT-PLUS END SEAL AFTER THE CONTINUITY TEST IS COMPLETE.

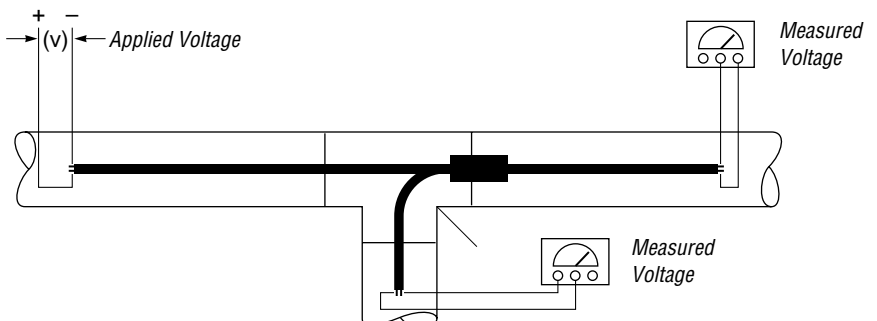

Visual Inspection

Visually inspect the HWAT-Plus system to ensure:

- Proper installation of the system.
- No mechanical damage, such as (cuts, burns, or scrapes).
- Proper connections (intact braid connections, splices, and tees).
- Tracing of all required piping with heating cable.

⚠ WARNING: DAMAGED HEATING CABLE *MUST* BE REPLACED. DO NOT ENERGIZE DAMAGED HEATING CABLE. FAILURE TO REPLACE DAMAGED HEATING CABLE CAN CAUSE ARCING OR FIRE.

Troubleshooting Guide

The troubleshooting guide that follows will lead you through potential problems. If a problem persists after you follow the guide procedures, contact your Raychem representative immediately.

Symptom	Possible Causes	Corrections
Circuit breaker trips.	Circuit breaker undersized.	Reestablish what the current loads are going to be and resize the breakers.
	Circuit oversized.	Check that maximum circuit length has not been exceeded. Check to see if existing bus-wire sizing is compatible with larger-size breaker.
	Defective circuit breaker.	Repair circuit breaker.
	Connections and/or splices shorting out.	Locate and repair the incorrect connections or splices.
Physical damage to the heating cable causing a short.	Physical damage to the heating cable causing a short.	Locate and remove damaged sections of heating cable. Megger per installation instructions.
		To locate shorting problems, follow these steps: <ul style="list-style-type: none">• Visually inspect the power connections, splices, and end seals for proper installation.• Check for visual indications of damage around the valves, pumps, and any area where there may have been maintenance work.• Look for crushed or damaged insulation along the pipe. If at this point you have not located the problem, start isolating one section of the heating cable from the other. (For example, cut the circuit in half and test each half to find the general area of damage, then remove the insulation to find the specific damaged area.)

Troubleshooting Guide (continued)

Symptom	Possible Causes	Corrections
Circuit breaker trips. (continued)	Bus wires connected at the end seal.	Remove end seal, disconnect the wires, and perform a current check for possible other damage.
	Excessive moisture in connection boxes or splices.	Dry out and reseal connections and splices. Megger per installation instructions.
	Nick or cut in heating cable or power feed wire with moisture present.	Locate and replace damaged power feed wire or heating cable. Verify that system passes megger test.
	Start up at too low a temperature.	Raise building temperature to minimum 60°F or run hot water through pipes.

**WARNINGS:**

1. TO PREVENT SHOCK OR PERSONAL INJURY, TURN OFF POWER AT THE CIRCUIT BREAKER BEFORE WORKING ON THE HEATING CABLE OR PIPING.



2. DAMAGED HEATING CABLE MUST BE REPLACED. DO NOT ENERGIZE DAMAGED HEATING CABLE. FAILURE TO REPLACE DAMAGED HEATING CABLE CAN CAUSE ARCING OR FIRE.

Symptom	Possible Causes	Corrections
Pipe temperatures are below design values.	Water heater thermostat or mixing valve set incorrectly.	Reset the thermostat or mixing valve.
	Water heater thermostat or heating element failure.	Check thermostat and heating element.
	Water heater not on.	Turn on water heater.
	Low- or no-input voltage.	Repair electrical supply lines and equipment.
	Splices or tees are not connected. Heating cable has been severed.	Check routing and length of heating cable (use "as built"). Connect the splices or tees, locate and replace the damaged heating cable, then recheck the power.
	Improper connection causing a high-resistance connection.	Reattach with the correct procedure.
	Heating cable exposed to excessive moisture.	Replace the heating cable.
	Heating cable exposed to excessive temperatures.	
	Insulation is wet.	Remove wet insulation and replace it with dry insulation; repair leaks in pipe.
	Insulation or ambient temperature not per specification.	Correct to requirements shown on page 11.
Pipe temperatures are above design value.	Heating cable not insulated per plans; cable left off some pipes.	Check plans and verify that cable is installed on all pipes and insulated correctly.
	Voltage to circuits is too high.	Power circuits at 208 Vac.
	Ambient temperature is too high.	Adjust building temperature within range shown on page 11.
	Pipe insulation is not as specified.	Install correct insulation per Insulation Schedule on page 12.

4. System operation

System Start-up

The start-up of an HWAT-Plus system is simple: once the heating cable has passed all megger and continuity tests, simply turn on the circuit breakers and wait approximately four hours for the water to warm up. For a faster start-up you can turn on the water heater and open the fixture at the end of the piping run until the water feels warm.

If your piping system is closed, such as by pressure-reducing valves or isolation valves, you must provide some method of pressure relief to allow for thermal expansion of the water during heat-up as specified in ANSI Z21.22.

If the circuit breakers trip, or the water does not warm up, refer to the Troubleshooting Guide on page 15.

Normal Operation

An HWAT-Plus system in operation will provide hot water without the noise, wide variation in temperature, or high energy costs associated with recirculation systems, and will operate trouble-free for years to come.

BE SURE THAT THE WATER HEATER OR MIXING VALVE IS SET AT THE TEMPERATURE NEEDED AT THE FIXTURE: 105°F (40°C), 115°F (45°C), 125°F (50°C), OR 140°F (60°C). THE WATER TEMPERATURE SHOULD ALWAYS REMAIN WITHIN 15°F OF THE CABLE TEMPERATURE. EXCEEDING THIS TEMPERATURE CAN SHORTEN THE HWAT-PLUS HEATING CABLE LIFE.

⚠ WARNING: TO PREVENT SHOCK OR PERSONAL INJURY, TURN OFF THE POWER AT THE CIRCUIT BREAKER BEFORE TESTING OR WORKING ON THE HEATING CABLE OR PIPING.

Periodic Inspection

The HWAT-Plus system has no moving parts and therefore requires no maintenance to keep the system operating. However, regular inspection and testing according to the following guidelines is recommended to ensure that the system has not been damaged:

- The system should be meggered annually. See Section 3, "System Testing", for the proper meggering procedure. This Megger check may be done at the circuit breaker panel or at the heating cable power connection. Record the readings on the chart at the end of this section.
- Where possible, visually inspect the pipe insulation and heating cable periodically to make sure that no physical damage has occurred.
- Periodically check the thermostat on the water heater or mixing valve. The HWAT-Plus system can be damaged by temperatures more than 15°F above the cable temperature rating. An HWAT-Plus system does not require overheating at the water heater in order to supply water at the correct temperature. Therefore, the water coming from the mechanical room should be at the desired temperature.
- The electrical equipment, such as circuit breakers, should be checked periodically. The ground fault feature should also be tested monthly. Record the results of this test on the chart at the end of this section.

Installation Testing Record

Building name: _____

Electrical contractor: _____

Mechanical contractor: _____

Completion date: _____

Test procedure	Initials & date	HWAT-Plus heating cable circuit number						
		1	2	3	4	5	6	7
Before splices & tees								
Megger (value)								
Before insulation								
Megger (value)								
Short circuit and continuity check								
Visual inspection								
Before Sheetrock								
Megger (value)								
Visual inspection								
Before start-up								
Megger (value)								

5. Installation responsibilities

The installation responsibilities on pages 27–39 should be copied and given to each specified trade.



The following pages show, by trade, the instructions for installing the HWAT-Plus system of heating cable and components. Proper installation of an HWAT-Plus system requires coordination among the various trades involved. The specification details many of these responsibilities, but cannot cover all of them. It is important that all parties agree on their responsibilities and understand the timing required. The general order of events is as follows:

1. Plans and specifications for the entire HWAT-Plus system are completed by the plumbing and electrical engineers.
2. Plumber installs the hot water piping.
3. Plumbing is pressure tested or otherwise checked for leaks.
4. Plumber designates the hot water pipes to be traced.
5. Heating cable is installed on the designated pipes.
6. HWAT-Plus components (such as splices, and tees) are installed.
7. Heating cable is meggered and checked for short circuits and continuity. (After short-circuit testing, install the end seals.)
8. Installer notifies the insulator when the heating cable installation has been completed.
9. Thermal insulation and "Electric Traced" labels are installed and component locations marked on the insulation.
10. Heating cable is tested for insulation resistance (meggered).
11. Wire and conduit is run to the heating cable.
12. Bare Sheetrock is installed.
13. The heating cable is meggered again before the bare Sheetrock is taped and sealed.
14. The system is turned on.

In a fast-track job, the HWAT-Plus system must be considered a critical path item: the pipe, heating cable, insulation, and Sheetrock must be installed in the proper order since the heating cable cannot be installed later. If, for example, the walls go up before the heating cable has been meggered, it may be necessary to remove the walls in order to repair the system.

Accidental damage to the system can be minimized during construction by installing thermal insulation on the pipe immediately after the pipe has been traced and the heating cable has been tested.

Read and observe the following to insure that the HWAT-Plus system is installed successfully.

⚠ WARNINGS:

- 1. TO MINIMIZE THE DANGER OF FIRE IF THE HEATING CABLE IS DAMAGED OR IMPROPERLY INSTALLED, USE A GROUND FAULT PROTECTION DEVICE WITH A NOMINAL 30-mA TRIP LEVEL. ELECTRICAL FAULT CURRENTS MAY BE INSUFFICIENT TO TRIP A CONVENTIONAL CIRCUIT BREAKER.**
- 2. DO NOT CONNECT THE BUS WIRES TOGETHER AT THE END SEAL. BUS WIRES OF THE SAME HEATER MUST NOT TOUCH EACH OTHER OR A SHORT CIRCUIT WILL RESULT.**
- 3. TO PREVENT SHOCK OR PERSONAL INJURY, TURN OFF THE POWER AT THE CIRCUIT BREAKER BEFORE WORKING ON THE HEATING CABLE OR PIPING.**
- ⚠ 4. WARNING: DAMAGED CABLE MUST BE REPLACED. DO NOT ENERGIZE DAMAGED HEATING CABLE. FAILURE TO REPLACE DAMAGED HEATING CABLE CAN RESULT IN ARCING OR FIRE.**

Continued on next page.

1. When making floor or wall penetrations, make sure the hole is large enough to accommodate the pipe *with thermal insulation*.
2. When sealing around pipes at floor penetrations (rat patches), care must be taken to avoid cutting the heating cable with a trowel, or getting the cable caught between the pipe and the concrete. The heating cable must *not* be embedded directly in the sealing material; the pipe should have thermal insulation over it (if allowed by local codes) or the heating cable should be run through the penetration in a tube or conduit. If the conduit must be sealed, use a pliable intumescent firestop material (Dow Corning Fire Stop, 3M Fire Barrier, or T&B Flame-Safe) that can be removed if necessary.



3. A torch must not be used on the pipe, pipe hangers, or riser clamps after the heating cable has been installed on the pipe because this can cause permanent damage to the heating cable (even if it does not appear to be burned). Use a saw, not a torch, to cut riser clamps. If use of a torch is unavoidable, move the HWAT-Plus cable by cutting the fiberglass tape that holds the cable to the pipe and pulling the heating cable away from the pipe, for at least 3 feet on either side of the area to be heated; the heating cable itself must not be cut. Shield the cable from the flame. Charred or damaged cable must be replaced to avoid the risk of fire.
4. Do not cut or scrape the heating cable.
5. Do not staple the insulation together; use tape. Staples will damage the heating cable.
6. Always test the heating cable with a Megger before and after covering the cable with insulation.
7. Complete the Power Connection Location Schedule in Section 4.
8. Submit this manual with completed forms to the owner.

Read and observe the following to insure that the HWAT-Plus system is installed successfully.

Before Heating Cable Installation

⚠ WARNING: DAMAGED CABLE MUST BE REPLACED. DO NOT ENERGIZE DAMAGED HEATING CABLE. FAILURE TO REPLACE DAMAGED HEATING CABLE CAN RESULT IN ARCING OR FIRE.

1. When making floor or wall penetrations for pipe runs, the holes or sleeves must be large enough to accommodate the insulation as well as the pipe.
2. Install the riser clamps so that they will fit inside the wall and will not have to be moved or cut later.

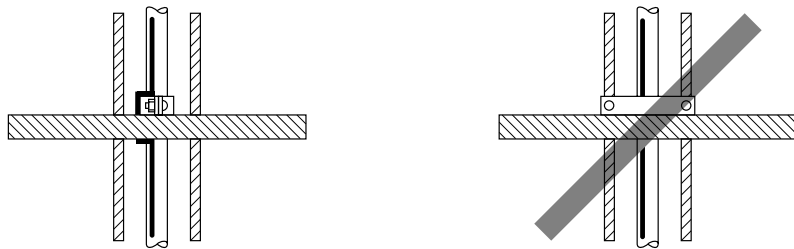

3. If possible, piping should be pressure-tested before installing the heating cable on the pipe. The connections and thermal insulation should not get wet.

After Heating Cable Installation

1. **Do not burn the HWAT-Plus cable. Overheating the cable can cause permanent damage, even if the cable does not appear to be burned.**
2. If a pipe support must be cut after the pipe has been traced, use a saw instead of a torch. If additional fittings or changes to the piping require brazing, pull the cable away from the pipe for 36 inches on either side of the fitting and shield the cable from the torch. This can be done by cutting the fiberglass tape that holds the heating cable to the pipe and pulling the heating cable away from the pipe; the heating cable itself must not be cut.



Continued on next page.

After Heating Cable Installation (continued)

⚠ WARNING: TO PREVENT SHOCK OR PERSONAL INJURY, TURN OFF THE POWER AT THE CIRCUIT BREAKER BEFORE WORKING ON THE HEATING CABLE OR PIPING.



3. Notify the design engineer if actual piping differs from the construction drawings. Note any variations on the shop drawings.
4. Identify the pipes to be traced. They may be spray painted red or simply marked on the plumbing drawings. Refer to the drawings and the HWAT-Plus Design Guide if you are uncertain which pipes need HWAT-Plus heating cable.



5. Set the water heater temperature controller or mixing valve at the desired system temperature: 105°F (40°C), 115°F (45°C), 125°F (50°C), or 140°F (60°C). **Never set the water temperature at more than 15°F (8°C) above the heating cable temperature:** this will shorten the life of the HWAT-Plus system.
6. Many temperature mixing valves require continuous flow across the sensing element for proper temperature control. If the plumbing system is equipped with a central temperature mixing valve, a small circulation loop around the valve may be required for the mixing valve to separate properly. Contact the mixing valve manufacturer for recommendations.

Preparation for Heating Cable Installation

Timing and coordination are critical with the HWAT-Plus system. Refer to page 26 of this section for the correct order of events.

1. Check all HWAT-Plus materials received to confirm that the proper materials are on site. HWAT-Plus heating cables can be identified by the label on the reel or the color-coded outer jacket (see Section 1).
2. Inspect the heating cable and components for in-transit damage. Continuity and insulation resistance tests on each reel are recommended. See Section 3 for test procedures.
3. Walk the system and plan the routing of the heating cable on the pipe. Remove any burrs or sharp edges along the route that could damage the heating cable. Confirm that wall and floor penetrations are sized properly.

Heating Cable Installation

WARNING: TO PREVENT SHOCK OR PERSONAL INJURY, TURN OFF THE POWER AT THE CIRCUIT BREAKER BEFORE WORKING ON THE HEATING CABLE OR PIPING.

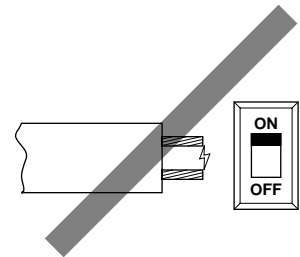
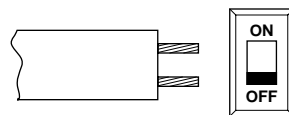

WARNING: DAMAGED CABLE MUST BE REPLACED. DO NOT ENERGIZE DAMAGED HEATING CABLE. FAILURE TO REPLACE DAMAGED CABLE CAN RESULT IN ARCING OR FIRE.



1. HWAT-Plus heating cable is always installed in straight runs. **Spiraling the heating cable is not necessary.**
2. On horizontal piping, run the heating cable along the lower section of the pipe (as shown) to protect it from damage.

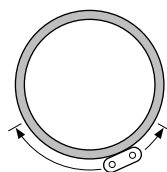

*Between "4 o'clock" and
"8 o'clock" positions*

Continued on next page.

Heating Cable Installation (continued)

3. On vertical piping groups, run the heating cable along the inside of the pipe close to other pipes so that the heating cable will not be damaged if the pipe hits the side of the floor penetration.

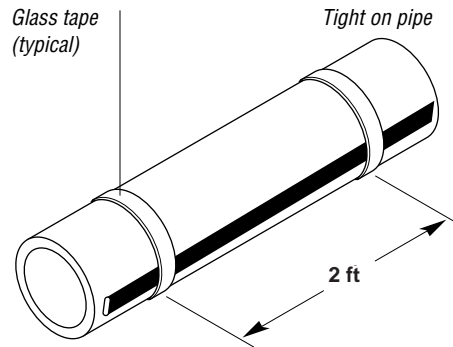
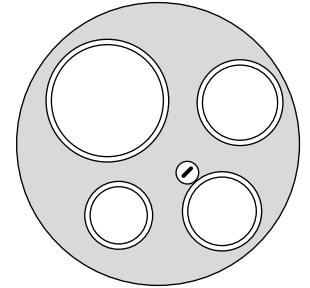
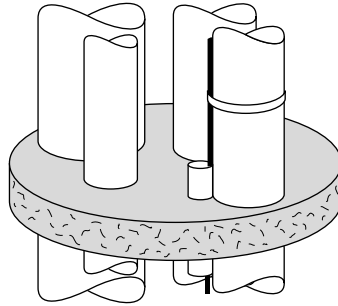

4. HWAT-Plus heating cable can be cut to length without affecting the heat output per foot.
5. The HWAT-Plus heating cable should be run on the outside (long) radius of the elbow.

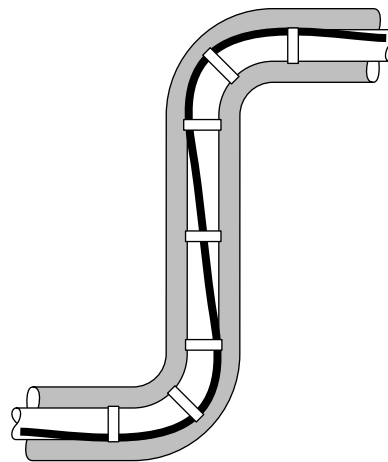

Continued on next page.

**Heating Cable Installation
(continued)**

6. Run the heating cable over the outside of the pipe support. Do not clamp the heating cable to the pipe with the pipe support.

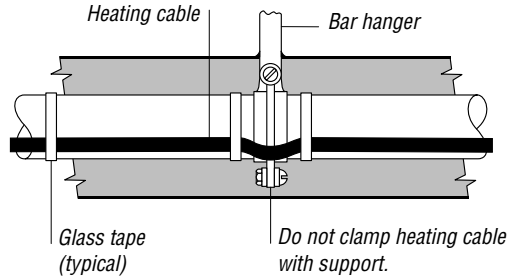

7. Typical System:

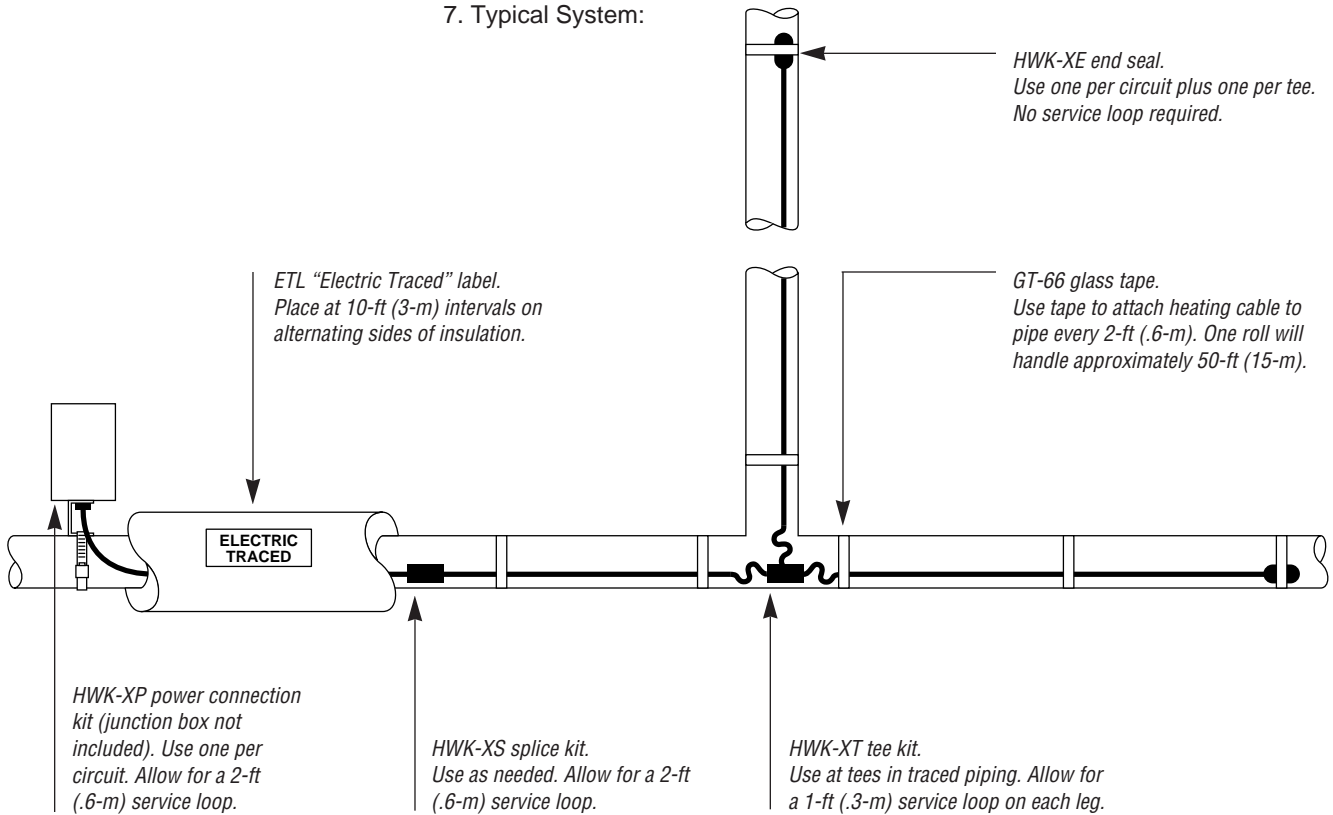

8. Where the HWAT-Plus heating cable is run past a thermostatic mixing valve, be careful to avoid contact between the heating cable and valve since this will affect the thermostat in the valve. Place insulation between the heating cable and the valve.
9. In high-rise construction it may be necessary to install the HWAT-Plus system 10 or 12 floors at a time to fit into the construction schedule. If so, the end of the heating cable should be sealed with an HWAT-Plus end seal and placed in an accessible location. This allows testing of one part of the heating cable at a time, and allows splicing it to another section when the system is complete.

Continued on next page.

Heating Cable Installation (continued)

10. Where the heating cable goes through a floor penetration ("rat patch") and is not included, protect the heating cable with a channel or conduit. This precaution will prevent damage to the heating cable and allow it to be removed if necessary.

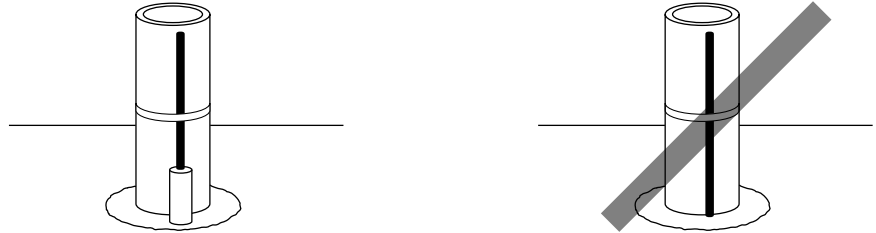

11. The connections and thermal insulation should not get wet.
12. Notify the design engineer if actual piping differs from the construction drawings. Note any variations.
13. Notify the insulator immediately after the heating cable installation is complete.
14. Noting any splices and tees in the circuits, complete the HWAT-Plus Circuit Schedule shown on page 21.

Component Installation

Raychem components are UL recognized and when used with the appropriate heating cable, are part of a UL-listed system. In order to meet UL requirements and have the system work properly, the installer must follow the instructions included with each component. In addition, the following warnings must be observed and the following precautions must be taken:

⚠ WARNING: DO NOT CONNECT THE BUS WIRES TOGETHER AT THE ENDSEAL. BUS WIRES OF THE SAME HEATER MUST NOT TOUCH EACH OTHER OR A SHORT CIRCUIT WILL RESULT.

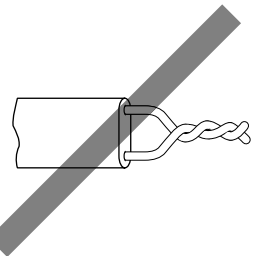

**⚠ WARNING:
DAMAGED OR IMPROPERLY INSTALLED COMPONENTS CAN
CAUSE ARCING OR FIRE.**

1. Do not burn, scorch, or blister the heat-shrink tubing used in the power connection. This could cause it to crack. Use low, even heating with a hot air gun or the yellow flame of a propane torch.
2. If the components are not installed immediately after the heating cable installation, the ends of the heating cable must be temporarily sealed to prevent water ingress. Use an HWAT-Plus end seal to seal the cable until the proper component can be installed. End seals cannot be reused.

Component Installation (continued)

3. All screws in component kits must be tightened completely in order to provide strain relief and a watertight seal.
4. Make sure the crimps or screw terminals have properly connected all wires and that none of the wires will pull out. It's easier to fix those connectors while making the kit than after it is enclosed and insulated.
5. Leave a service loop at each power connection, splice and tee. The additional heating cable will easily pay for itself in time savings if it becomes necessary to check or replace a component after installation. Splices and tees should use a service loop on each of the heating cables entering the component. Recommended service loops are:

Tee	3 feet (1 foot per leg)
Splice	2 feet (1 foot per leg)
Power connection	2 feet

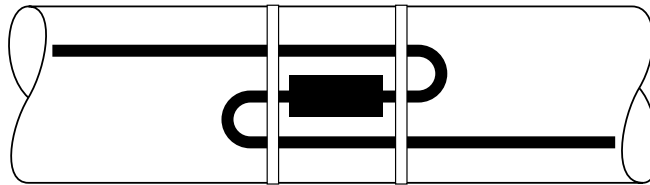

System Testing

All test procedures are described in Section 3 of this manual. It is the installer's responsibility to perform these tests or have an electrician perform them. Record the results in the Installation Testing Record in Section 4.

1. These tests must be done after installing HWAT-Plus splices and tees, but *before* the thermal insulation is applied to the pipe:
 - Insulation resistance (Megger) test
 - Short circuit and continuity test
 - Visual inspection
2. After the thermal insulation has been installed on the pipe, the following tests must be performed:
 - Insulation resistance test
 - Visual inspection
3. After the Sheetrock has been installed, but before it's taped and sealed, an insulation resistance test must be performed on the circuits. Record and submit the results in the Installation Testing Record in Section 4.

The HWAT-Plus system being installed on the hot water pipes requires that the following precautions be taken to ensure a good installation.

⚠ WARNING: DAMAGED CABLE MUST BE REPLACED. DO NOT ENERGIZE DAMAGED HEATING CABLE. FAILURE TO REPLACE DAMAGED HEATING CABLE CAN CAUSE ARCING OR FIRE.

1. Before insulating the pipe, visually inspect the heating cable and components for correct installation and damage.
2. Check insulation type and thickness against design specification, or consult page 12 for insulation data. Note that oversized insulation is required on 1¼ inch and smaller pipe sizes to fit over cable.
3. Insulate the pipes *immediately* after the heating cable is installed and has passed all tests. This is essential to minimize damage to the HWAT-Plus heating cable.
4. Insulate the pipe at floor and wall penetrations. Failure to do so will cause cold spots in the water system and could lead to damage to the heating cable. If local codes do not allow this, the heating cable should be run through a conduit or channel before the firestop is installed. Use a pliable intumescent sealing compound such as Dow Corning Fire Stop, 3M Fire Barrier, or T&B Flame-Safe.
5. **Do not use staples to close the insulation; use tape. Use of staples will damage the HWAT-Plus heating cable.**

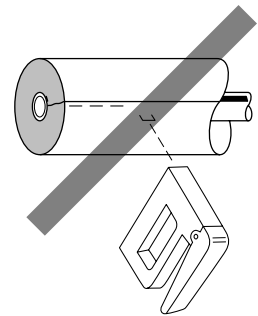
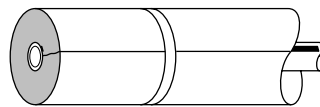

6. Mark on the outside of the insulation the location of splices, tees, and end seals as they are being covered by the insulation. Large diameter insulation or sheets may be used to cover splices, tees, or service loops.

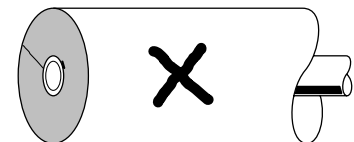

7. Make sure that all heat-traced piping, fittings, wall penetrations, and branch piping is insulated. Correct temperature maintenance requires properly installed and dry thermal insulation. Uninsulated sections of pipe will result in cold spots.
8. After installing insulation, install "Electric Traced" labels along piping at suitable intervals (10-foot intervals recommended) on alternate sides.

Power Supply and Electrical Protection

The HWAT-Plus system being installed in this building must be installed properly. The key points to remember during installation are summarized below.



WARNING: DO NOT CONNECT THE BUS WIRES TOGETHER AT THE SEAL. BUS WIRES OF THE SAME HEATER MUST NOT TOUCH EACH OTHER OR A SHORT CIRCUIT WILL RESULT.

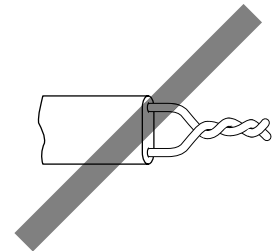

WARNING: TO MINIMIZE THE DANGER OF FIRE IF THE HEATING CABLE IS DAMAGED OR IMPROPERLY INSTALLED, USE A GROUND FAULT PROTECTION DEVICE WITH A NOMINAL 30-mA TRIP LEVEL.

ELECTRICAL FAULT CURRENTS MAY BE INSUFFICIENT TO TRIP A CONVENTIONAL CIRCUIT BREAKER. Square-D QOEPD and QOBEPD breakers or Westinghouse QPGFEP and QBGFEP breakers can meet this requirement for circuits up to 30 amps.

1. Voltage at the power connection must be 208 volts. Consult the factory regarding other voltages.
2. Circuit breakers must be sized for overcurrent protection according to the electrical requirements outlined on page 13. Do not exceed the maximum circuit length. Use circuit breakers that incorporate 30 mA ground-fault circuit protection.
3. Complete the HWAT-Plus Circuit Schedule in Section 4 of this manual.

Heating Cable Testing

Component Installation

The electrical contractor must coordinate with the installing contractor to perform the required tests as described in Section 4. Record the test results on the Installation Testing Record in Section 4.

Raychem components are UL recognized and when used with the appropriate heating cable, are part of a UL listed system. In order to meet UL requirements and have the system work properly, the instructions included with each component must be followed. Also observe the following warning and



WARNING: DAMAGED OR IMPROPERLY INSTALLED COMPONENTS CAN CAUSE ARCING OR FIRE.

1. Do not burn, scorch, or blister the heat-shrinkable tubing. This could cause it to crack. Use low, even heating with a hot air gun or the yellow flame of a propane torch.

Component Installation (continued)

2. If the components are not installed immediately after the heating cable installation, the ends of the heating cable must be temporarily sealed to prevent water ingress. Use an HWAT-Plus end seal, which must later be cut off. End seals cannot be reused.
3. All screws in component kits must be tightened completely in order to provide strain relief and a watertight seal.
4. Make sure the crimps and screw terminals have properly connected all wires and that none of the wires will pull out. It is easier to fix those connectors while making the kit than after it is enclosed and insulated.
5. Leave a "service loop" of extra cable at each component. The additional heating cable will easily pay for itself in time savings if it becomes necessary to check or replace a component after installation. Splices and tees should use a service loop on each of the heating cables entering the component.

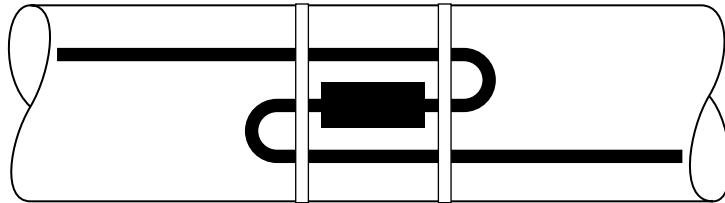

Because dry-wall screws are sharp enough to damage both the pipes and the HWAT-Plus heating cable, the HWAT-Plus system that is being installed on the hot water pipes requires that the following warning be observed and precautions taken to ensure a good installation.

⚠ WARNING: DAMAGED CABLE MUST BE REPLACED. DO NOT ENERGIZE DAMAGED HEATING CABLE. FAILURE TO REPLACE DAMAGED HEATING CABLE CAN RESULT IN ARCING OR FIRE.

1. Do not put up walls unless the plumbers, electricians, and insulators have completed their work on the HWAT-Plus system in that area.
2. Do not damage the pipes behind the walls. If the pipe, insulation, or HWAT-Plus cable is damaged, it may require the wall to be removed in order to repair the system.
3. If a pipe clamp interferes with wall installation, have the plumber move it. Do not cut off the clamp with a torch; this will damage the HWAT-Plus heating cable and require the wall to be removed in order to replace the heating cable.
4. Do not tape and seal Sheetrock until the electrician has completed testing of the HWAT-Plus system in that area.

*Raychem is a registered trademark and HWAT-Plus is a trademark of Raychem Corporation.
Megger is a trademark of Avo Biddle Instruments.
Sheetrock is a registered trademark of United States Gypsum Company.*

All of the information in this booklet, including illustrations, is believed to be reliable. Users, however, should independently evaluate the suitability of each product for their application. Raychem makes no warranties as to the accuracy or completeness of the information, and disclaims any liability regarding its use. Raychem's only obligations are those in the Standard Terms and Conditions of Sale for this product, and in no case will Raychem be liable for any incidental, indirect, or consequential damages from the sale, resale, use, or misuse of the product.

Raychem Corporation
Construction Products Group
300 Constitution Drive
Menlo Park, California 94025-1164
(800) 272-9243 ext.1512
Fax (415) 361-2656

Raychem Canada Ltd.
3245 American Drive
Mississauga
Ontario, Canada LV4 1N4
(800) 387-3993
Fax (416) 671-0972