

## AMC-1B Line-sensing thermostat for nonhazardous locations

### Installation Instructions

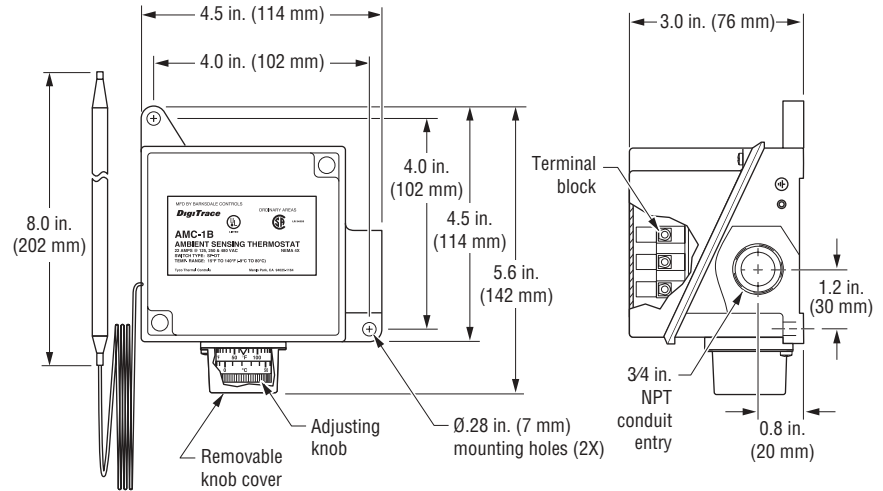
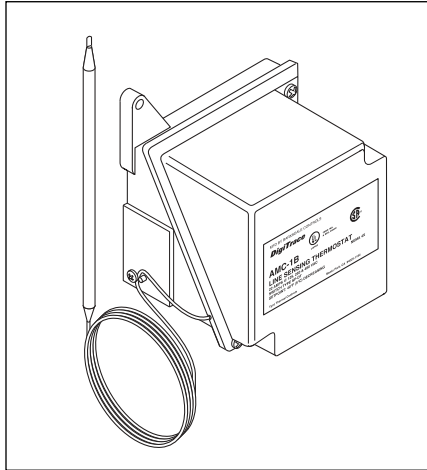

#### Description

The AMC-1B thermostat is designed for controlling heat-tracing systems in nonhazardous locations. The AMC-1B can be used to

control heat-tracing circuits in a pipe-sensing mode (see Figure 1 on back), to indicate low-temperature (Figure 2) or high temperature

(Figure 3) alarm conditions, or to control the coil on a contactor (Figure 4).

#### Specifications

Enclosure	NEMA 4X, polyurethane-coated cast-aluminum housing, stainless-steel hardware
Entries	One 3/4" NPT conduit hub
Set point range	25°F to 325°F (–4°C to 163°C)
Sensor exposure limits	–40°F to 420°F (–40°C to 215°C)
Housing exposure limits	–40°F to 160°F (–40°C to 71°C)
Switch	SPDT
Electrical rating	22 A at 125/250/480 Vac
Accuracy	±6°F (±3.3°C)
Deadband	2°F to 12°F (1.1°C to 6.7°C) above actuation temperature
Set point repeatability	±3°F (±1.7°C)
Sensor type	Fluid-filled (silicone) bulb and 9 ft (2.7 m) capillary
Sensor material	300 series stainless steel
Connection terminals	Screw terminals, 10–14 AWG (2–5 mm <sup>2</sup> )

#### Approvals



#### ⚠ WARNING:

This component is an electrical device. It must be installed correctly to ensure proper operation and to prevent shock or fire. Read these

important warnings and carefully follow all the installation instructions. Component approvals and performance are

based on the use of specified parts only. Do not use substitute parts or vinyl electrical tape to make connections.

## AMC-1B Installation Instructions

### Thermostat Installation Instructions

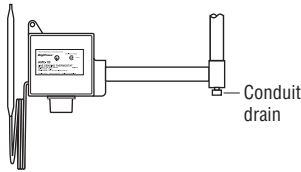

1. Verify that the thermostat is suitable for the area where it is to be installed.
2. Check the line voltage and the heat-tracing load to ensure that the thermostat ratings are not exceeded.
3. Mount the unit using unistrut or the Raychem Universal Mounting Bracket (UMB-263757) in a position that prevents condensation from draining into the enclosure from the connecting conduit (see diagram at left).

### Positioning the Sensor Bulb

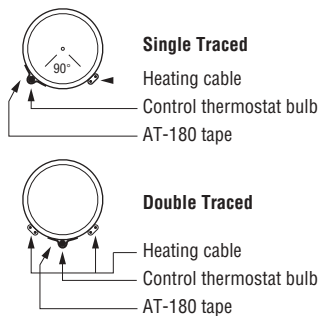

4. Position the bulb in the lower quadrant of the pipe as shown in the diagrams to the left. **Place the bulb at least three feet from pipe supports, valves, or other heat sinks; protect the capillary from kinks or bends less than 1/2 inch in radius.**
5. Tape the bulb firmly to the pipe with AT-180 aluminum tape, making sure there is no air space between the bulb and pipe. **Do not overlap the bulb and heating cable with the same piece of AT-180 tape.**
6. For metal-tank-wall sensing, use the BCK-35 bulb clamp (purchased separately from Raychem) and install the clamp per the instructions provided. Make sure there is no air space between the tank wall and the bulb. For installation on plastic tanks, contact Tyco Thermal Controls at (800) 545-6258.

### Setting the Thermostat

7. Set the thermostat dial to the desired temperature, then finish wiring.
8. Complete insulating. Do not turn the system on until the bulb is covered with thermal insulation.
9. Fill the piping or tank. Once the thermostat has begun to cycle, check the fluid temperature with an immersed thermostat (best for plastic systems) or an accurate temperature indicator. Adjust the dial setting, if necessary.

### Wiring

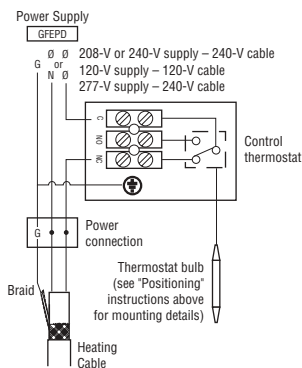

Figure 1. Pipe-sensing

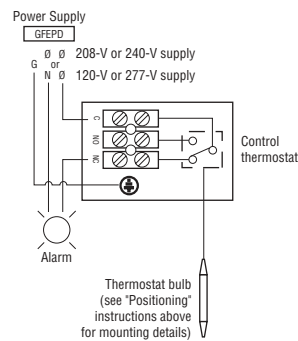

Figure 2. Low-temperature alarm

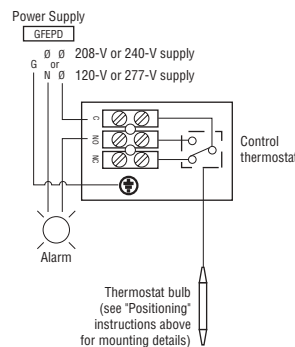

Figure 3. High-temperature alarm

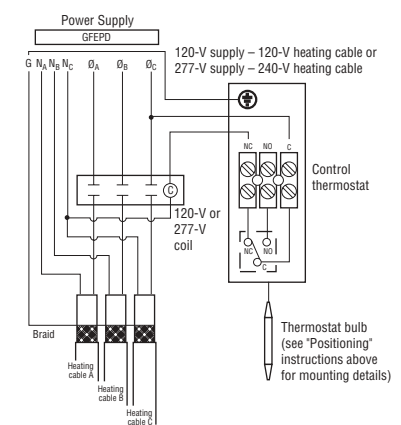

Figure 4. Contactor control  
For switching heat-tracing loads greater than 22 A or switching multiple heat-tracing circuits.

### Worldwide Headquarters

**Tyco Thermal Controls**  
300 Constitution Drive  
Menlo Park, CA 94025-1164  
USA  
Tel (800) 545-6258  
Fax (650) 474-7517  
Fax-on-Demand (800) 329-4494  
info@tycothermal.com  
www.tycothermal.com

**Important:** All information, including illustrations, is believed to be reliable. Users, however, should independently evaluate the suitability of each product for their particular application. Tyco Thermal Controls makes no warranties as to the accuracy or completeness of the information, and disclaims any liability regarding its use. Tyco Thermal Controls' only obligations are those in the Tyco Thermal Controls Standard Terms and Conditions of Sale for this product, and in no case will Tyco Thermal Controls or its distributors be liable for any incidental, indirect, or consequential damages arising from the sale, resale, use, or misuse of the product. Specifications are subject to change without notice. In addition, Tyco Thermal Controls reserves the right to make changes—without notification to Buyer—to processing or materials that do not affect compliance with any applicable specification.