

## High Profile End Seal Boot

### Installation Instructions

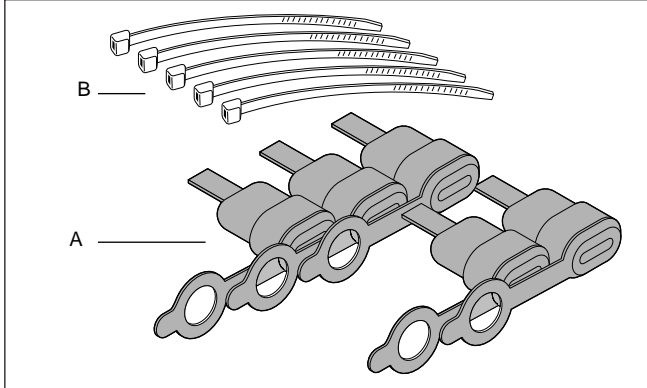

#### Description

The E-100-BOOT-5/PACK kit contains five replacement boots for use with the E-100 end seals. Boots may be reused repeatedly but must be replaced whenever they are damaged or the sealant appears dry or contaminated or is missing. These boots must be used with the entire E-100 end seal kit; they must not be used alone.

This kit may be installed at temperatures as low as  $-40^{\circ}\text{F}$  ( $-40^{\circ}\text{C}$ ). For easier installation, store kit above freezing until installation.

For technical support call Raychem at (800) 545-6258.

#### Tools Required

- Wire cutters

#### Kit Contents

| Item | Qty | Description |
|------|-----|-------------|
| A    | 5   | Boots       |
| B    | 5   | Cable ties  |

#### ⚠ WARNING:

This component is an electrical device which must be installed correctly to ensure proper operation and to prevent shock or fire. Read these important warnings and carefully follow all of the installation instructions.

- To minimize the danger of fire from sustained electrical arcing if the heating cable is damaged or improperly installed, and to comply with the requirements of Raychem and the 1996 National Electrical Code, ground-fault equipment protection must be used on each heating cable branch circuit. Arcing may not be stopped by conventional circuit protection.
- Component approvals and performance are based on the use of specified parts only. Do not substitute parts or use vinyl electrical tape.

- The black heating-cable core is conductive and can short. It must be properly insulated and kept dry.
- Keep components and heating cable ends dry before and during installation.
- Damaged bus wires can overheat or short. Do not break braid or bus wire strands when scoring the jacket or core.
- Bus wires will short if they contact each other. Keep bus wires separated.
- Use only fire-resistant insulation materials such as fiberglass wrap.
- Leave these installation instructions with the user for future reference.

#### ⚠ CAUTION:

Health Hazard. Prolonged or repeated contact with the sealant in the core sealer may cause skin irritation. Wash hands thoroughly. Overheating or burning the sealant will produce fumes that may cause polymer fume fever. Avoid contamination of cigarettes or tobacco. Consult MSDS RAY/5510 for further information.

CHEMTREC 24-hour emergency telephone:  
(800) 424-9300.

Non-emergency health and safety information:  
(650) 361-4907.

## E100-BOOT-5-PACK High Profile End Seal Kit Boot Installation Instructions

**1**

- Turn off power.
- Clip cable-tie and remove.

**⚠ WARNING: Shock Hazard.**  
Conductors will be exposed.  
Re-entry should be performed by a qualified electrician.  
Follow standard electrical lock-out procedures before opening end seal.

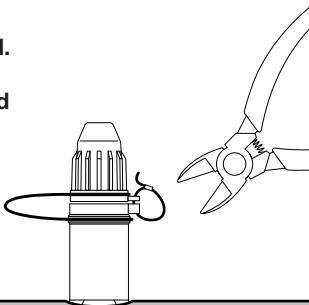

**END SEAL**  
ELECTRIC TRACED  
Raychem

**2**

- Unscrew cap from end seal stand.

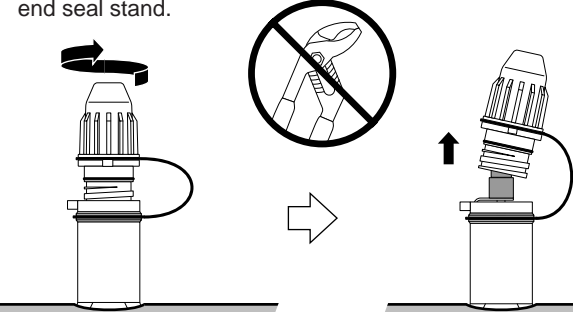

**END SEAL**  
ELECTRIC TRACED  
Raychem

**END SEAL**  
ELECTRIC TRACED  
Raychem

**3**

- Grasp boot and remove.

**⚠ CAUTION: Health Hazard.** Wash hands after contact with sealant.  
Consult MSDS RAY/5510.

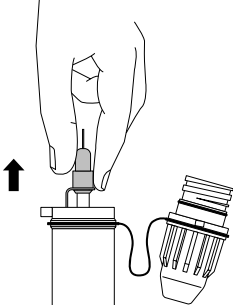

**END SEAL**  
ELECTRIC TRACED  
Raychem

**4**

- Place loop of new boot around the cable.
- Push boot onto the end of the cable until it bottoms out.

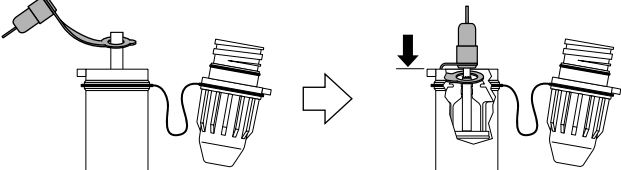

**END SEAL**  
ELECTRIC TRACED  
Raychem

**END SEAL**  
ELECTRIC TRACED  
Raychem

**5**

- Secure loop in groove around the strain relief.

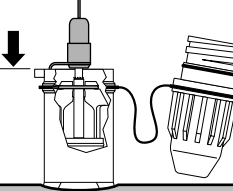

**END SEAL**  
ELECTRIC TRACED  
Raychem

**6**

- Hand tighten cap onto end seal stand.
- Install new cable tie.

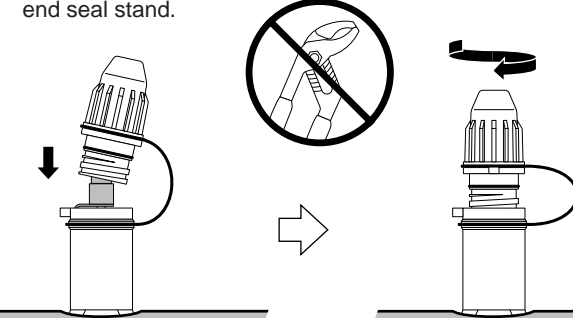

**END SEAL**  
ELECTRIC TRACED  
Raychem

**END SEAL**  
ELECTRIC TRACED  
Raychem

**Raychem Corporation**  
Chemelex Division  
300 Constitution Drive  
Menlo Park, California 94025-1164  
Tel (800) 545-6258  
Fax (650) 361-6711  
cheminfo@raychem.com

**Raychem Canada Ltd.**  
Suite 4900  
40 King Street West  
Toronto, Ontario M5H 4A2  
Canada  
Tel (800) 545-6258  
Fax (800) 988-5172

**Raychem S.A.I.C.**  
Carlos Pellegrini 1163, Piso 7  
1011 Capital Federal  
Buenos Aires, Argentina  
Tel (54) 1/394-5150  
Fax (54) 1/326-9985