

**Heat-tracing controller configuration and monitoring software**

The DigiTrace Supervisor™ (DTS) heat-tracing controller configuration and monitoring software provides a graphical user interface for DigiTrace communications and controller products. The software supports one or more NGC-UIT, NGC-30-CRM or CRMS, 780 Series/GCC-9000 Group Communications Controllers, DigiTrace T2000 AC 2000+ alarm/communications interface cards, and most DigiTrace Controllers supporting the ModBus® protocol.

DTS allows central configuration and monitoring of any DigiTrace controller installed

in the field that includes the appropriate communications interface.

Full featured alarm monitoring with the ability to acknowledge and clear alarms is provided. Advanced features such as data logging & trending, batch & recipe processing, scheduled events, etc. are also incorporated into the software

The Enterprise edition of the software adds full multi-user, multi-server and networking capabilities. Electric Heat-Tracing (EHT) system information can now be accessed and managed from almost anywhere in the

world, using the latest connectivity technologies. This flexibility can reduce the cost of installing communications to controllers within your facility. Devices are no longer limited to simple hard-wired serial communications, but can now take advantage of existing network infrastructures including Ethernet LANs (Local Area Networks) and Internet-based WANs (Wide Area Networks).

DigiTrace Supervisor — a powerful, integrated management tool for your Electric Heat-Tracing system.

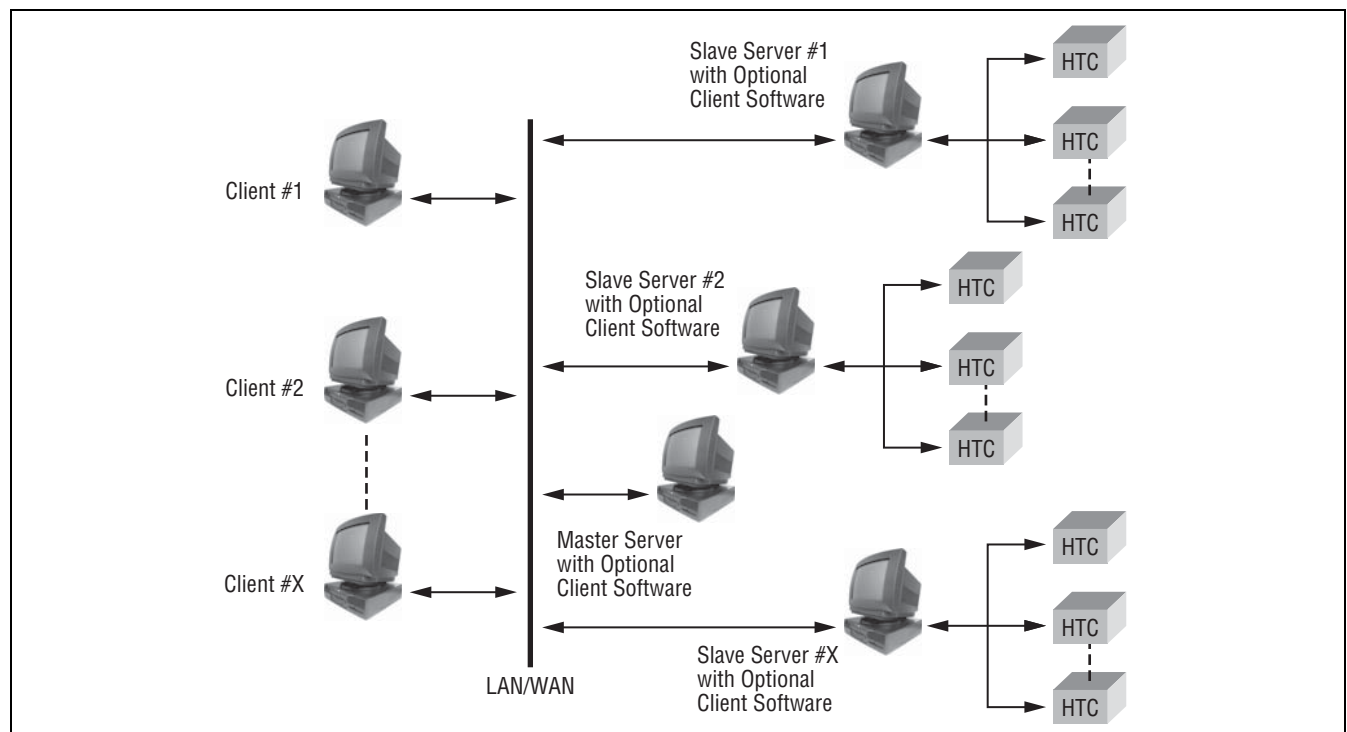

Typical Single Master, Multi-Slave Server, Multiple Client System

---

**Specifications**

---

**System requirements**

To install and run the software, you will need:

- Master Server Computer:
  - Pentium® 4– 2.4 GHz or faster (Recommended), Pentium® III– 500 MHz (Minimum) IBM-compatible personal computer
  - A hard disk with at least 500 megabytes of free space (Recommended), 150 megabytes (Minimum)
  - 1 gigabyte of RAM (Recommended), 256 megabytes of RAM (Minimum)
- Slave Server Computer(s) (Optional):
  - Pentium® 4– 1 GHz or faster (Recommended), Pentium® III– 300 MHz (Minimum) IBM-compatible personal computer
  - A hard disk with at least 150 megabytes of free space (Recommended), 50 megabytes (Minimum)
  - 256 megabytes of RAM (Recommended), 128 megabytes of RAM (Minimum)
- Client Computer(s):
  - Pentium® III– 500 MHz or faster (Recommended), Pentium® II– 300 MHz (Minimum) IBM-compatible personal computer
  - A hard disk with at least 50 megabytes of free space
  - 256 megabytes of RAM (Recommended), 128 megabytes of RAM (Minimum)
- CD-ROM drive
- 1 or more available serial ports (for Master or Slave Computers that connect to field devices)
- A mouse or other compatible pointing device
- SVGA display with 800x600 resolution
- Microsoft Windows® XP Pro, XP Home or 2000 (Slave & Client Computers)
- Microsoft Windows® 2000 Server or Microsoft Windows® 2003 Server (SQL Masters)
- Microsoft .NET Framework version 1.1
- Network Connectivity

**Registration**

DigiTrace Supervisor will run in DEMO mode for up to 14 days until you register and activate the software. For more information about how to register, see the *DigiTrace Supervisor Operations Manual (H57576)*.

**Controller compatibility**

This software is compatible with any of the following controllers that have the appropriate communications interface installed:

- NGC-UIT with NGC-30-CRM and -CRMS Controllers
- 910/915/920 Series HTCs
- T2000 systems using AC2000+ communication interfaces
- Legacy systems using GCC-9000/780 Series group communications controllers:
  - 720/HTC-9000/HTC-9000 CAS HTCs
  - 790/HTC-9100 Series HTCs
  - T2000 systems using AC2000 communication interfaces

**Specifications**

**Feature comparison table**

- = Full or enhanced support
- = Limited support

		DigiTrace Supervisor V2.1 Enterprise	DigiTrace Supervisor V2.1	DigiTrace Supervisor V2.0 Multi - User/Server	DigiTrace Supervisor V2.0	DigiTrace Supervisor V1.3	PyroMaster V1.2	TraceMaster
<b>Product Support</b>	NGC-UIT, NGC-30 Controllers	••	••					
	910/915/920 Series Controllers	••	••	••	••	••	•	•
	T2000 Controllers	••	••	••	••	••	••	••
	Legacy Devices (780/GCC, 720/790/-9000/-CAS/-9100 HTCs)	••	••	••	••	••	••	••
<b>HTC Connectivity</b>	Serial (RS-232, RS-485)	••	••	••	••	••	••	•
	Ethernet	••	••	••	••	••	•	
	Support for extended addressing	••	••	••	••	••	••	
	Unique Communications Settings per Device	••	••	••	••			
<b>System Features</b>	Multi-Level security	••	••	••	••	••	••	•
	System Management by Plant Group	••	••	••	••			
	Product Configuration	••	••	••	••	••	••	•
	Real-time Monitoring <sup>1</sup>	••	••	••	••	••	••	••
	Alarm Scanning/Logging	••	••	••	••	••	••	••
	Individual User-defined Preferences	••	••	••	••			
	Multi-Level Device Alarm Priorities	••	••	••	••			
<b>Data Management</b>	Enhanced Documentation	••	••	••	••	••		••
	Drawing Viewer <sup>2</sup>	••	••	••	••	••	••	••
	Data Logging & Trending	••	••	••	••	••		•
	Data Import/Export <sup>3</sup>	••	••	••	••	••		
	Visual and Printed Reports	••	••	••	••	••	••	••
	Database Utilities	••	••	••	••	••		•
	History Logging	••	••	••	••	••	•	•
	System-wide Data Synchronization	••	••	••	••	••	••	
	Internal User Messaging	••	••	••	••			
<b>Automation</b>	Batches	••	••	••	••	••		•
	Recipes	••	••	••	••	••		
	Event Scheduler	••	••	••	••	••		
	Email on Alarm	••	••	••	••	••	•	
	Offline Modes	••	••	••	••	••		•
	Automated Steam-Out Feature	••	••	••	••			
<b>Networking</b>	Multi-User Connections	••	• <sup>4</sup>	••	• <sup>4</sup>			
	Muti-server Architectures	••		••				
	Remote Connectivity (LAN/WAN+VPN)	••	••	••	••			
	Administration Tools	••	••	••	••			

<sup>1</sup> V2: Including multiple devices in one screen.

<sup>2</sup> V2: Support for user-defined view/drawing application.

<sup>3</sup> V2: XML-based data transfer.

<sup>4</sup> Limited to 4 Users (Clients)